

PENDANT STATIONS

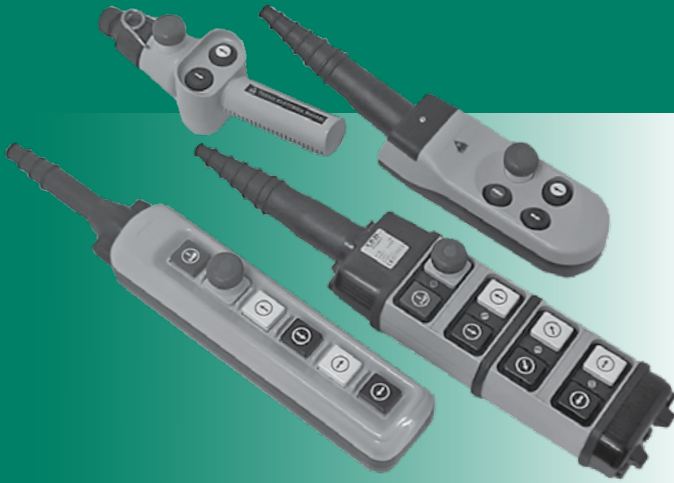

Springer Controls is the North American distributor for the Italian based company Tecno Elettrica Ravasi®. T.E.R. is a world leader in the manufacturing of Crane & Hoist Controls. We offer 4 models of pendant stations. Each offers outstanding quality, versatile designs, and rugged dependability. All pendant models can be custom made to fit your specifications.

PENDANT STATIONS

Charlie Pendant; Economical • 2 to 3 button control • 1, 2 speed switches

Charlie Pendant Control Station.....	M2
Dimensions.....	M3
Accessory Parts and Technical Data.....	M4, M5
Maintenance Instructions.....	M6
Request Form - Non-Standard Pendant Stations.....	M7

Alpha Pendant; Ergonomic size & shape • 2 - 12 button, double column • 1, 2 speed switches

Alpha Pendant Control Station.....	M8
Dimensions.....	M9
Accessory Parts and Technical Data.....	M10-M12
Maintenance Instructions.....	M13
Request Form - Non-Standard Pendant Stations.....	M14

NPA Pendant; Custom availability • 2 - 12 button, single column • 1, 2, 3 speed switches

NPA Pendant Control Station.....	M16
Dimensions.....	M17
Accessory Parts and Technical Data.....	M18-M21
Maintenance Instructions.....	M22
Request Form - Non-Standard Pendant Stations.....	M23

SPA Pendant; Heavy-duty design • 2 - 20 button, double column • 1, 2 speed switches

SPA Pendant Control Station.....	M24
Dimensions.....	M25
Accessory Parts and Technical Data.....	M26-M29
Maintenance Instructions.....	M30
Request Form - Non-Standard Pendant Stations.....	M31

CHARLIE PENDANT STATION

M₂

Charlie Pendant Control Station

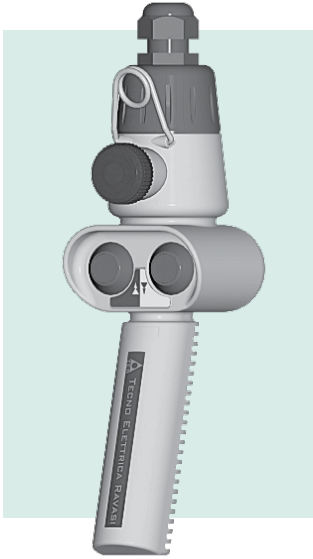

The **Charlie Series Pendant Station** is a low cost, ergonomic design for one hand operation of up to three buttons. A patented unique clamshell design allows the installer the convenience of opening the unit without external screws, clamps, etc. Lightweight, easy to hold, provides one hand control of numerous equipment functions.

- Economical
- 2 to 3 button control
- 1, 2 speed switches
- IP65 rated

Charlie Pendant Control Station - Part No. & Pricing

No. Buttons	ASSEMBLY			Part No.	Price
	E - Stop	1 Speed	2 Speed		
	1 N.C.	1 N.O. + 1 N.O. + com	1 N.O. + 1 N.O. + 1 N.O. + com		
2		2		PF39020001	\$125.00
			2	PF39020002	\$135.00
3	1	2		PF39030001	\$140.00
	1		2	PF39030002	\$150.00

* Custom Units available - Part Number assigned by factory; PF390 _ J _ _ _ _
See request form page M7

Charlie Pendant - Dimensions (mm)

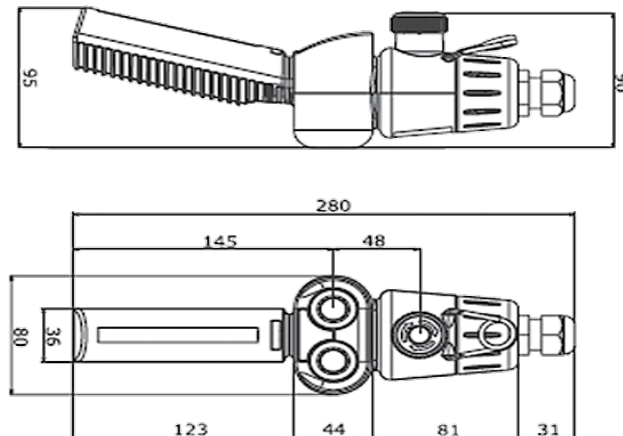

Discount Schedule SC-20

Charlie Pendant - Detailed Drawing *

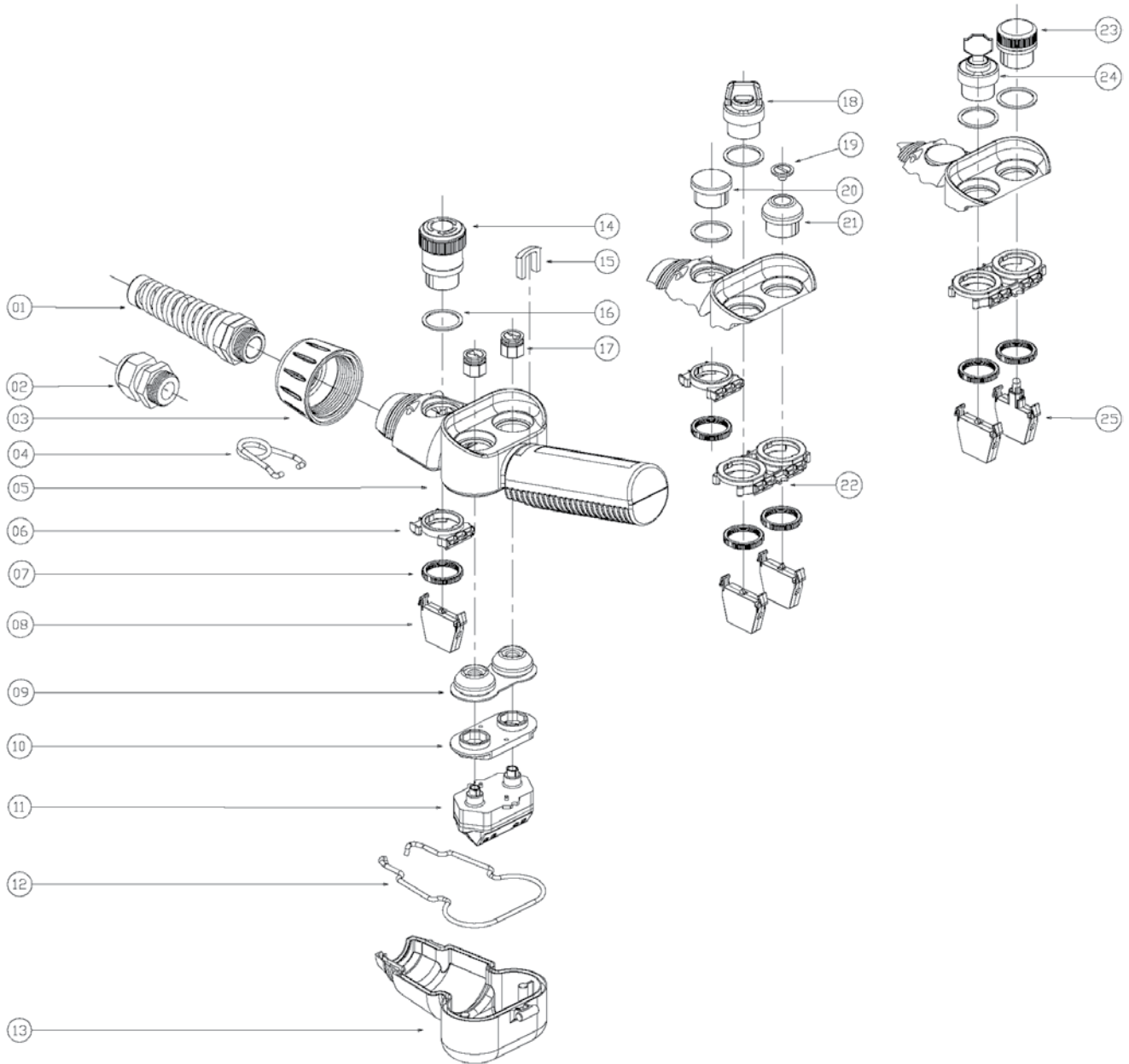











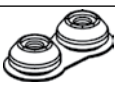

* See page M4 for spare part pricing













CHARLIE PENDANT - ACCESSORY PARTS

Spare Parts

M 4

Reference	Illustration	Description	Part No.	Price
01		Spiral Cable Clamp	PRPS0025PE	\$32.00
08		1 N.O. Switch 1 N.C. Switch	PRSL1000PI PRSL1001PI	\$40.00
09		Rubber Boot for Double Push-Button (without buttons)	PRG0020PE	\$20.00
11		1-Speed Double Switch 2-Speed Double Switch	PRSL1002PI PRSL1003PI	\$52.00 \$90.00
14		Emergency Stop Mushroom Push-Button	PRSL1011PI	\$94.00
17		Button for Double Push-Button	PRTA2xxxPI*	\$12.50
18		Spring Return Selector Switch (on-off) Selector Switch (on-off)	PRSL1015PI PRSL1016PI	\$77.00
		Spring Return 3-Position Selector Switch 3-Position Selector Switch	PRSL1026PI PRSL1027PI	\$90.00
19		Button for Single Push-Button	PRTA1xxxPI*	\$11.00
20		Blanking Plug	PRSL1023PI	\$32.00
21		Single Push-Button (without button)	PRSL1010PI	\$22.00
23		Red Pilot Light Yellow Pilot Light Green Pilot Light	PRSL1012PI PRSL1013PI PRSL1014PI	\$63.00
24		Key Selector Switch (on-off)	PRSL1017PI	\$99.00
25		Lamp Holder (12V or 24V only)	PRSL1004PI	\$63.00

*Standard Buttons

						
PRTA1000PI PRTA2000PI	PRTA1001PI PRTA2001PI	PRTA1002PI PRTA2002PI	PRTA1003PI PRTA2003PI	PRTA1004PI PRTA2004PI	PRTA1005PI PRTA2005PI	PRTA1006PI PRTA2006PI
						
PRTA1007PI PRTA2007PI	PRTA1010PI PRTA2010PI	PRTA1011PI PRTA2011PI	PRTA1012PI PRTA2012PI	PRTA1013PI PRTA2013PI	PRTA1030PI PRTA2030PI	

Discount Schedule SC-20

Technical Specifications

Conformity to Community Directives	73/23/CEE	93/68/CEE		
Conformity to Standards	EN 60204-1 EN 60529	EN 60947-1 EN 418	EN 60947-5-1 EN 50013	IEC 536
Ambient Temperature	Storage Operational	-40° C / +70° C -25° C / +70° C		
Protection Degree	IP 65			
Insulation Category	Class II			
Cable Entry	Cable Clamp PG16			
Operating Positions	Any Position			
Weight	~ 320g			
Approvals	CE			

Technical Specifications of Contact Switches

Utilisation Category	AC 15
Rated Operational Current	3 A
Rated Operational Voltage	250V
Rated Thermal Current	10 A
Rated Insulation Voltage	500V ~
Mechanical Life	0,5 x 10 ⁶ operations
Terminal Referencing	According to EN 50013
Connections	Screw-Type Terminals
Approvals	CE - UL - cUL
Operating Force	2.0 - 2.4 lbs

Features of the Contact Switches

The single switches PRSL1000PI and PRSL1001PI have 1 N.C. contacts with 2 connecting terminals.

The double switch PRSL1002PI (1-speed)) has:

1 N.O. contact with 1 connecting terminal for the first speed for each opposite function - 1 single terminal for both functions

The double switch PRSL1003PI (2-speeds) has:

1 N.O. contact with 1 connecting terminal for the first speed for each opposite function - 1 N.O. contact with 1 connecting terminal for the second speed for both functions - 1 single terminal for both functions.

All N.C. contacts are of the positive opening operation type.
The switches have the following reference for internal wiring.

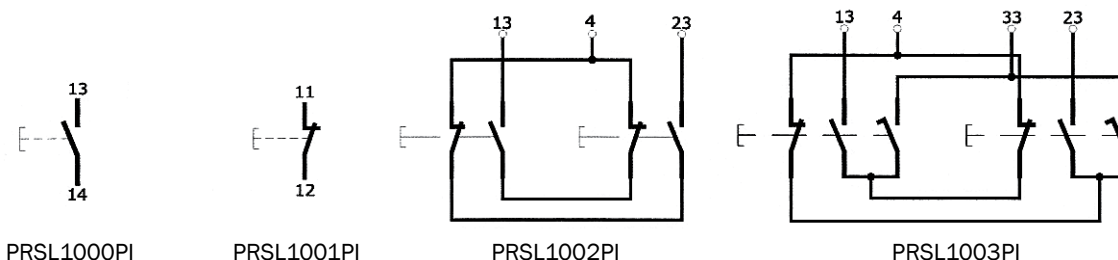

CHARLIE PENDANT - MAINTENANCE INSTRUCTIONS

M 6

Use & Maintenance Instructions

The **Charlie Pendant Control Station** is an electromechanical device for low voltage control circuits (EN 60947-1, EN60947-5-1) to be used as electrical equipment on machines (EN 60204-1) in compliance with the fundamental requirements of the Low Voltage Directive 73/23/CEE and of the Machine Directive 89/392/CEE.

The pendant station is designed for industrial use and also for use under particularly severe climactic conditions (operational temperature -25°C to +70°C, suitable for use in tropical environment). The equipment is not suitable for use in environments with potentially explosive atmosphere, corrosive agents or a high percentage of sodium chloride (saline fog). Oils, acids or solvents may damage the equipment.

The switches (08, 11) are designed for auxiliary control of contactors or electromagnetic loads (utilisation category AC-15 according to EN 60947-5-1). Do not connect more than one phase to each switch (08, 11). Do not oil or grease the control elements (14, 17, 18, 21, 24) or the switches (08, 11).

The installation of the pendant station shall be carried out by an expert and trained personnel. Wiring shall be properly done according to current instructions.

Prior to installation and the maintenance of the pendant station, the main power of the machinery shall be turned off.

Steps for the proper installation of the pendant station

- unscrew and remove the front ring (03) and the cable clamp (02)
 - open the lower cover (13)
 - insert the cable into the cable clamp (02) to a length suitable for wiring the switches
 - strip the cable to a length suitable for wiring the switches (08, 11)
 - tape the stripped part of the cable
- connect all the switches (08, 11) according to the contact scheme printed on the switches (tighten the wires into the terminals with a torque equal to 0.6 Nm; insertability of wires into the switch terminals equal to 2 x 1.5mm² - 1 x 2.5mm²).
- screw the front ring (03) to close enclosure and lower cover (13) (check the proper positioning of the coupling pin of the lower cover (13) and of the rubber (12))
 - tighten the cable clamp (02) on the cable tight enough to guarantee protection against water and/or dust

Periodic Maintenance Steps

- check the proper tightening of the front ring (03)
- check the proper tightening of the cable clamp (02)
- check the proper tightening of the switch (08, 11) terminal screws
- check all wiring (in particular where wires clamp into the switches)
- check the conditions of the rubber (12) fit into the lower cover (13) and of the rubber of the control elements (09,21)
- check that the plastic enclosure (03, 05, 13) of the pendant station is not broken

In case any component of the pendant station is modified, the validity of the markings and the guarantee on the equipment are annulled. Should any component need replacement, use original spare parts only.













Springer Controls declines all responsibility for damages caused by the improper use or installation of the equipment.

Request Form for Non-Standard Pendant Stations

Instructions:

- Write the number corresponding to the **control element** required (broken line box). When buttons are required and when necessary, mark the direction of the arrow into the corresponding circle.
- Selector Switches PRSL1026PI and PRSL1027PI can be assembled only in the center-top position. (3 position switches)
- Write the number corresponding to the single or double switches.
- Mark the appropriate box to show either the **spiral cable clamp** or the **cable clamp (PG16)**. Cable clamp comes standard.

Control Elements

1  (green)	8 	14 PRSL1009PI - Mushroom Pushbutton	20 PRSL1017PI - Key Selector Switch (on-off)
2  (green)	9 	15 PRSL1012PI - Red Pilot Light	21 PRSL1026PI - Spring Return 3 Pos. Selector Sw.
3  (yellow)	10 	16 PRSL1013PI - Yellow Pilot Light	22 PRSL1027PI - 3 Position Selector Switch
4  (red)	11 	17 PRSL1014PI - Green Pilot Light	23 PRSL1023PI - Blanking Plug
5 	12 	18 PRSL1015PI - Spring Return Selector Sw (on-off)	24 PRSL1024PI - Spring Return Key Selector Sw. (2 pos.)
6 	13 	19 PRSL1016PI - Selector Switch (on-off)	
7 			

Single Switches

1 PRSL1000PI - 1 N.O.

2 PRSL1001PI - 1 N.C.

3 PRSL1004PI - Lamp Holder (12V or 24V)

Double Switches

1 PRSL1002PI - 1 speed

2 PRSL1002PI - 2 speed

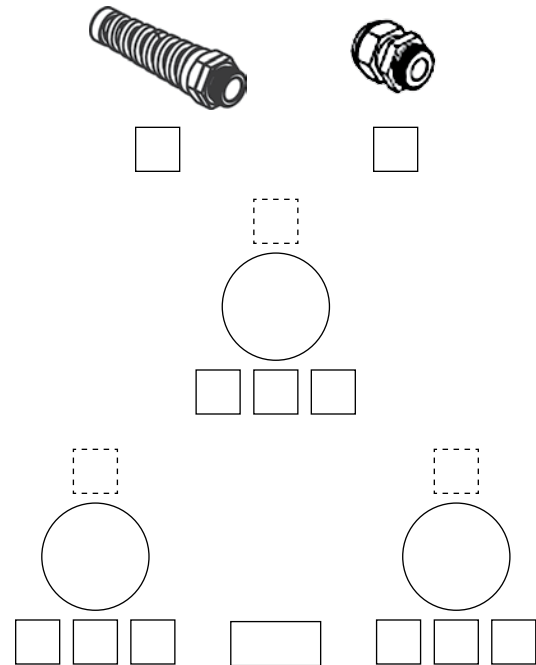

Remarks:

.....

.....

.....

.....

.....

Springer Controls - Fax: 904-225-9084

ALPHA PENDANT CONTROL STATION

M8

Alpha Pendant Control Station



The **Alpha Series Pendant Station** is the latest ergonomic design in 2 column pendant stations. Using symbols for button identification, this rubber gasketed unit provides a solid feel and immediate response. Available in 1 or 2 speeds and multiples up to 12 buttons, it is a very compact, lightweight station. A NEMA 4 rated polycarbonate enclosure is a striking yellow and black design. It provides the operator with a pendant that fits firmly in the hand but will not create fatigue to the operator.

- Convenient, ergonomic size & shape
- 2 to 12 button, double column
- 1, 2 speed switches
- IP65 rated

Alpha Pendant - Part No. & Pricing*

No. Buttons	Assembly			Standard Part No.	Price
	E-Stop	Start/Reset	1 Speed		
	1 N.C.	1 N.O.	1 N.O. + 1 N.O. + com		
2			2	PF38020001	\$197.00
3	1		2	PF38030001	\$278.00
4	1	1	2	PF38040002	\$305.00
4			4	PF38040004	\$231.00
5	1		4	PF38050003	\$312.00
6	1	1	4	PF38060001	\$513.00
8	1	1	6	PF38080001	\$542.00
9	1		8	PF38090001	\$569.00
10	1	1	8	PF38100001	\$643.00
12	1	1	10	PF38120001	\$672.00

* Custom units available - Part number assigned by factory; #PF38 __ _ J _ _ _ (see request form on page M14)

Discount Schedule SC-20

ALPHA PENDANT CONTROL STATION - DIMENSIONS

M9

Alpha Pendant Control Station - Dimensions

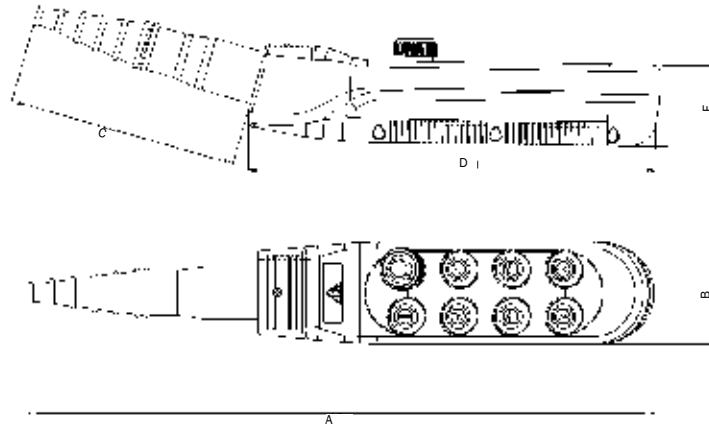

No. of Buttons	Weight (lbs.)	Overall Dimensions (in)				
		A	B	C	D	E
2, 4	1.04	15.04	2.95	6.65	8.66	2.36
6, 8	1.59	18.11	2.95	6.65	11.89	2.36
10, 12	1.96	21.14	2.95	6.65	15.04	2.36

Standard Alpha Button Configuration

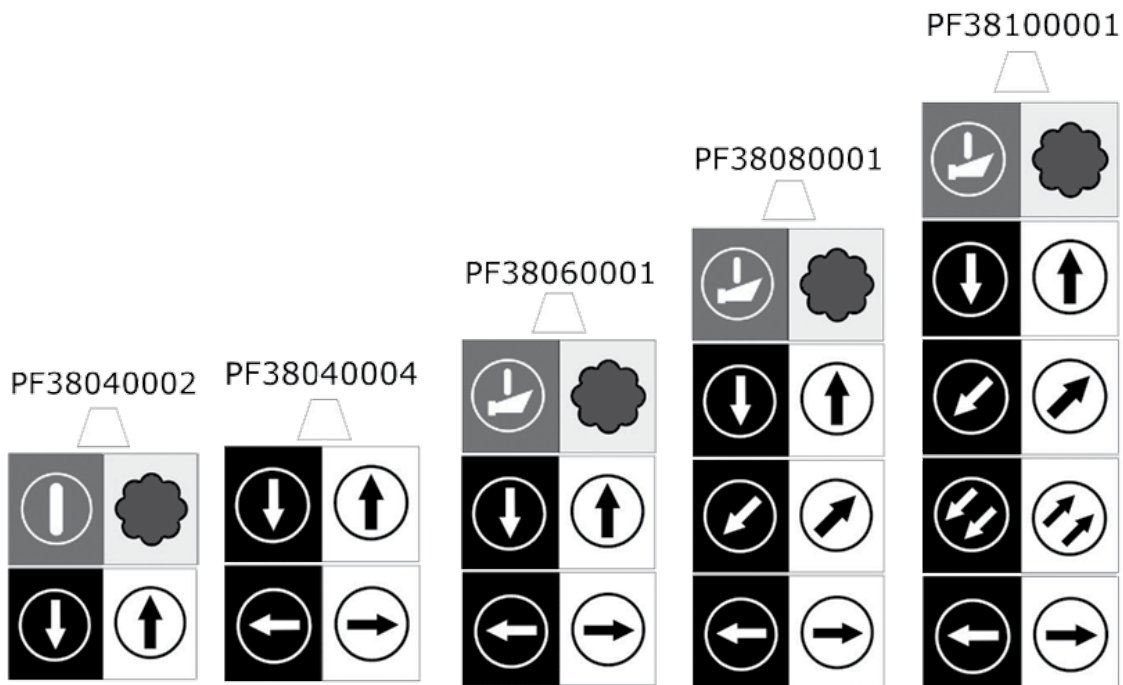

* 2, 3, 5, 12 Alpha Pendants also available

ALPHA PENDANT - ACCESSORY PARTS

M 10

Alpha Pendant - Standard Buttons

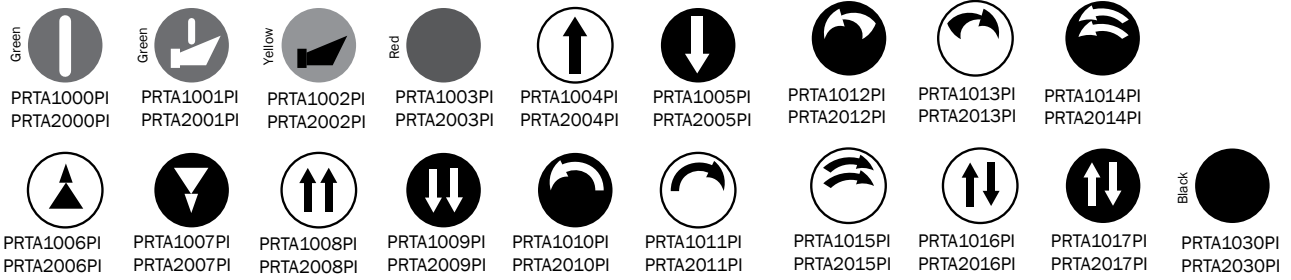



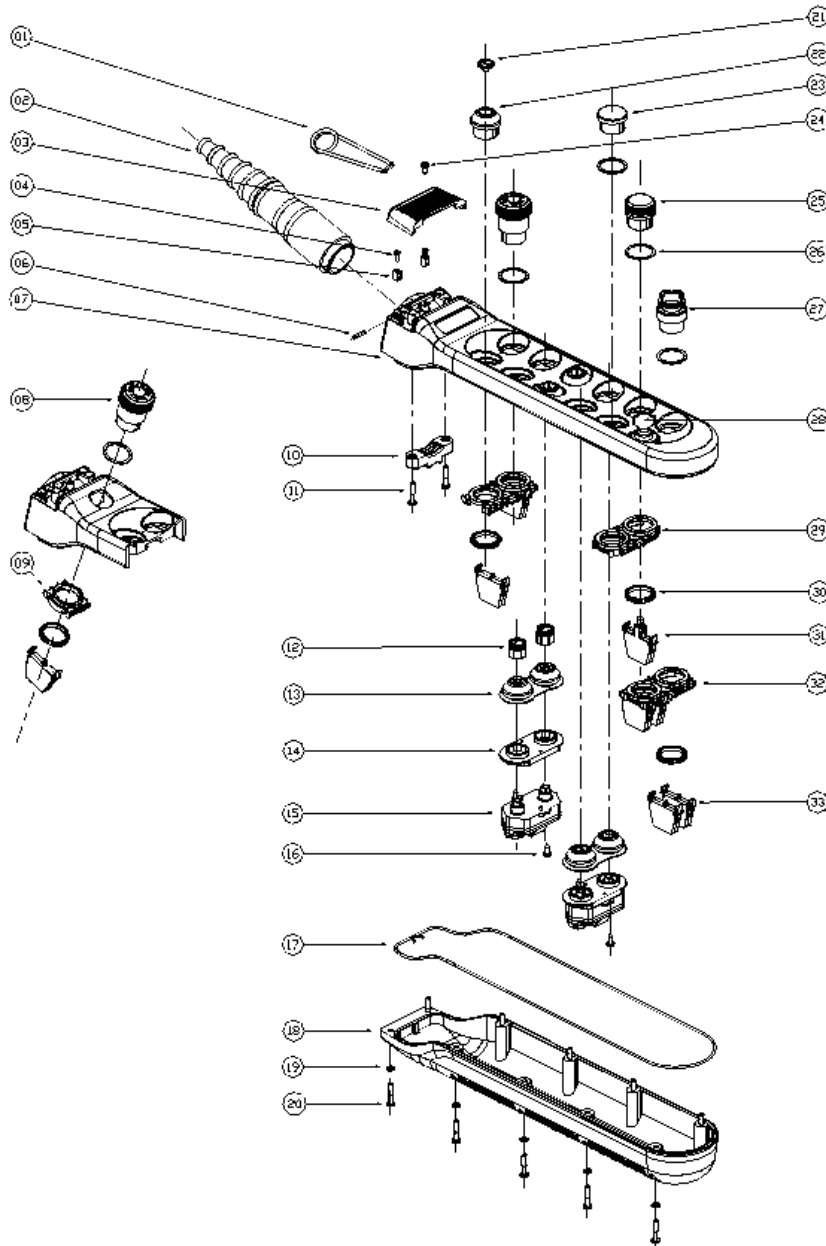











Alpha Pendant - Detailed Drawing



* See page M11 for spare part pricing

Spare Parts

Reference	Illustration	Description	Part No.	Price
01		Hook	PRGA0012PE	\$5.50
02		Cable Sleeve	PRSL0145PE	\$68.00
08		Emergency Stop Mushroom Push-Button	PRSL1011PI	\$94.00
12		Button for Double Push-Button	PRTA2xxxPI (see standard buttons)	\$12.50
13		Rubber for Double Push-Button (without buttons)	PRG00020PE	\$20.00
15		1-Speed Double Switch	PRSL1002PI	\$52.00
		2-Speed Double Switch	PRSL1003PI	\$90.00
21		Button for Single Push-Button	PRTA1xxxPI (see standard buttons)	\$11.00
22		Single Push-Button (without Button)	PRSL1010PI	\$22.00
23		Blanking Plug	PRSL1023PI	\$32.00
25		Red Pilot Light Yellow Pilot Light Green Pilot Light	PRSL1012PI PRSL1013PI PRSL1014PI	\$63.00
27		Spring Return Selector Switch (on-off) Maint. Selector Switch (on-off)	PRSL1015PI PRSL1016PI	\$77.00
		Spring Return 3-Position Selector Switch Maint. 3-Position Selector Switch	PRSL1026PI PRSL1027PI	\$90.00
28		Maint. Key Selector Switch (on-off)	PRSL1017PI	\$99.00
31		Lamp Holder (12V or 24V only)	PRSL1004PI	\$63.00
33		1 N.O. Switch 1 N.C. Switch	PRSL1000PI PRSL1001PI	\$40.00

Discount Schedule SC-20

ALPHA PENDANT - TECHNICAL DATA

M 12

The space available for the conductors is dimensioned for a 48 x 1.5 mm² cable. All switches have terminals facing the cable clamp of the pendant station and screws on the opposite side to facilitate wiring. All electronic connections use screw-type terminals. The Emergency Stop Mushroom Pushbutton complies with the EN 418 standard and is equipped with positive opening N.C. switches.

Technical Specifications

Conformity to Community Directives	73/23/CEE	93/68/CEE		
Conformity to Standards	EN 60204-1 EN 60529	EN 60947-1 EN 418	EN 60947-5-1 EN 50013	IEC 536
Ambient Temperature	Storage Operational	-40 °C / +70 °C -25 °C / +70 °C		
Protection Degree	IP 65			
Insulation Category	Class II			
Cable Entry	Rubber Cable Sleeve (Ø 14÷26 mm)			
Operating Positions	Any Position			
Weight	~ 320g			
Approvals	CE, c CSA us			

Technical Specifications of Contact Switches

Utilisation Category	AC 15
Rated Operational Current	3 A
Rated Operational Voltage	250V
Rated Thermal Current	10 A
Rated Insulation Voltage	500V ~
Mechanical Life	0,5 x 10 ⁶ operations
Terminal Referencing	According to EN 50013
Connections	Screw-Type Terminals
Approvals	UL - cUL

Features of the Contact Switches

The single switches PRSL1000PI and PRSL1001PI have 1 N.O. or 1 N.C. contact with 2 connecting terminals.

The double switch PRSL1002PI (1-speed)) has:

1 N.O. contact with 1 connecting terminal for the first speed for each opposite function - 1 single terminal for both functions

The double switch PRSL1003PI (2-speeds) has:

1 N.O. contact with 1 connecting terminal for the first speed for each opposite function - 1 N.O. contact with 1 connecting terminal for the second speed for both functions - 1 single terminal for both functions.

All N.C. contacts are of the positive opening operation type. The switches have the following reference for internal wiring.

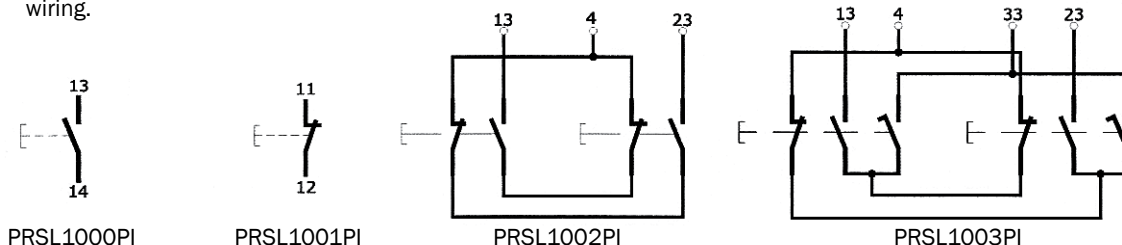

ALPHA PENDANT - MAINTENANCE INSTRUCTIONS

M13

Use & Maintenance Instructions

The **Alpha Pendant Control Station** is an electromechanical device for low voltage control circuits (EN 60947-1, EN60947-5-1) to be used as electrical equipment on machines (EN 60204-1) in compliance with the fundamental requirements of the Low Voltage Directive 73/23/CEE and of the Machine Directive 89/392/CEE.

The pendant station is designed for industrial use and also for use under particularly severe climactic conditions (operational temperature -25 °C to +70 °C, suitable for use in tropical environment). The equipment is not suitable for use in environments with potentially explosive atmosphere, corrosive agents or a high percentage of sodium chloride (saline fog). Oils, acids or solvents may damage the equipment.

The switches (24, 42) are designed for auxiliary control of contactors or electromagnetic loads (utilisation category AC-15 according to EN 60947-5-1). Do not connect more than one phase to each switch (24, 42). Do not oil or grease the control elements (19, 21, 31, 36, 37) or the switches (24, 42).

The installation of the pendant station shall be carried out by an expert and trained personnel. Wiring shall be properly done according to current instructions.

Prior to installation and the maintenance of the pendant station, the main power of the machinery shall be turned off.

Steps for the proper installation of the pendant station

- remove the screws on the enclosure (27) to open the pendant station
- cut the variable selection rubber cable sleeve (5) and insert the cable tight enough to guarantee protection against water and/or dust.
- fix the cable to the cable sleeve (5) using a cable tie (not supplied).
- strip the cable to a length suitable for wiring the switches (24, 42)
- tape the stripped part of the cable
- connect all the switches (24, 42) according to the contact scheme printed on the switches (tighten the wires into the terminals with a torque equal to 0.6 Nm; insertability of wires into the switch terminals equal to 2 x 1.5mm² - 1 x 2.5mm²).
- close the pendant station checking the proper positioning of the rubber (26) in the enclosure (27).

Additional steps for the installation of self-supporting cables

- remove the small cover (03) screwed on the cover of the pendant station.
- put the terminals (05) into their seats and insert the suspension wires of the self-supporting cable.
- pull the suspension wires to obtain the right inclination of the pendant station and screw the wires into the terminals (05).
- close the small cover (03) and put the exceeding suspension wires in the seats next to the terminals (05).

Periodic Maintenance Steps

- check the proper tightening of the screws (29) of the enclosure (15, 27)
- check the proper tightening of the switch (24, 42) terminal screws,
- check the wiring conditions (in particular where wires clamp into the switches)
- check the conditions of the rubber (26) fit into the enclosure (27), of the rubber of the control elements (22, 31) and of the cable sleeve (05).
- check that the plastic enclosure (15, 27) of the pendant station is not broken

In case any component of the pendant station is modified, the validity of the markings and the guarantee on the equipment are annulled. Should any component need replacement, use original spare parts only.

Springer Controls declines all responsibility for damages caused by the improper use or installation of the equipment.

ALPHA PENDANT REQUEST FORM



















Request Form for Non-Standard Alpha Pendant Stations

M 14

Instructions:

- Write the number corresponding to the **control element** required (broken line box). When buttons are required and when necessary, mark the direction of the arrow into the corresponding circle.
- Write the number corresponding to the single **or** double switches.
- Mark the appropriate box to show where the cable sleeve must be assembled (top or bottom)

Control Elements

<input type="checkbox"/> 1  (green)	<input type="checkbox"/> 8 	<input type="checkbox"/> 15 
<input type="checkbox"/> 2  (green)	<input type="checkbox"/> 9 	<input type="checkbox"/> 16 
<input type="checkbox"/> 3  (yellow)	<input type="checkbox"/> 10 	<input type="checkbox"/> 17 
<input type="checkbox"/> 4  (red)	<input type="checkbox"/> 11 	<input type="checkbox"/> 18 
<input type="checkbox"/> 5 	<input type="checkbox"/> 12 	<input type="checkbox"/> 19 
<input type="checkbox"/> 6 	<input type="checkbox"/> 13 	
<input type="checkbox"/> 7 	<input type="checkbox"/> 14 	

- | | |
|---|--|
| <input type="checkbox"/> 20 PRSL1009PI - Mushroom Pushbutton | <input type="checkbox"/> 26 PRSL1017PI - Key Selector Switch (on-off) |
| <input type="checkbox"/> 21 PRSL1012PI - Red Pilot Light | <input type="checkbox"/> 27 PRSL1023PI - Blanking Plug |
| <input type="checkbox"/> 22 PRSL1013PI - Yellow Pilot Light | <input type="checkbox"/> 28 PRSL1014PI - Spring Return Key Selector Sw. |
| <input type="checkbox"/> 23 PRSL1014PI - Green Pilot Light | <input type="checkbox"/> 29 PRSL1026PI - Spring Return 3 Pos. Selector Sw. |
| <input type="checkbox"/> 24 PRSL1015PI - Spring Return Selector Sw (on-off) | <input type="checkbox"/> 30 PRSL1027PI - 3 Position Selector Switch |
| <input type="checkbox"/> 25 PRSL1016PI - Selector Switch (on-off) | |

Single Switches		Double Switches	
<input type="checkbox"/> 1	PRSL1000PI - 1 N.O.	<input type="checkbox"/> 1	PRSL1002PI - 1 speed
<input type="checkbox"/> 2	PRSL1001PI - 1 N.C.	<input type="checkbox"/> 2	PRSL1002PI - 2 speed
<input type="checkbox"/> 3	PRSL1004PI - Lamp Holder (12V or 24V)		

Hook

Cable Sleeve

Single

Single Double Single

Single Double Single

Single Double Single

Single Double Single

Single Double Single

Single Double Single

Single Double Single

Cable Sleeve

Remarks:.....

.....

.....

NPA PENDANT STATION

M 16

NPA Pendant Station



The **NPA Series Pendant Station** is the leader in versatility and rugged design. With a choice of operators from 2 to 12, and a selection of up to 3 speed contacts, selector switches and pilot lights as well as potentiometers, the NPA leads the way for the industry. Economical in cost, flexible in choice of operators, and using the latest in new polymers, it has become the standard both indoors or outside in rugged weather.

- Custom availability
- 2 to 12 button, single column
- 1, 2, 3 speed switches
- IP65 rated

NPA Pendant Station - Part No. & Pricing*

No. Buttons	Assembly			Standard Part No.	Price
	E-Stop	Start/Reset	1 Speed		
	1 N.C.	1 N.O.	1 N.O. + 1 N.O. + com		
2			2	PF03020005	\$206.00
3	1		2	PF03030004	\$327.00
4	1	1	2	PF03040105	\$365.00
4			4	PF03040022	\$426.00
6	1	1	4	PF03060293	\$479.00
8	1	1	6	PF03080201	\$583.00
10	1	1	8	PF03100334	\$675.00
12	1	1	10	PF03120282	\$764.00

* Custom units available - part number assigned by factory; PF03 __ J ____. See request form on page M23.

Discount Schedule SC-20

NPA Pendant - Dimensions

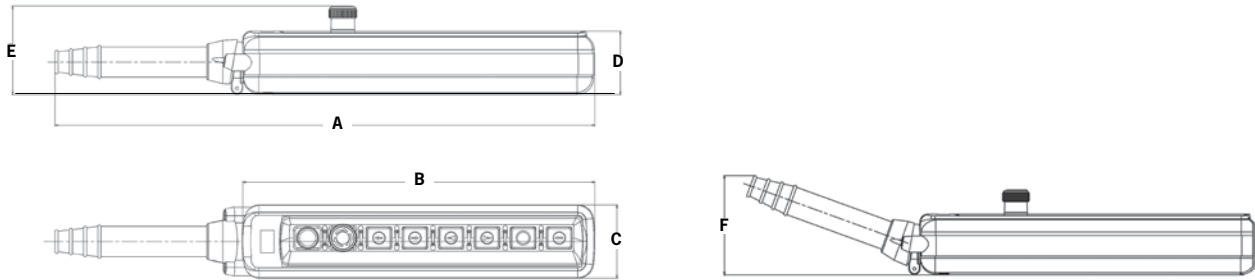

No. of Buttons	Weight (lbs)	Overall Dimensions (inches)					
		A	B	C	D	E	F
2	.99	11.50	5.51	3.00	2.76	3.90	3.43
3	1.21	13.11	7.13	3.00	2.76	3.90	3.43
4	1.43	14.65	8.74	3.00	2.76	3.90	3.43
6	1.98	18.07	12.09	3.00	2.76	3.90	3.43
8	2.65	23.82	15.47	3.27	2.76	3.90	4.57
10	3.09	26.97	18.66	3.27	2.76	3.90	4.57
12	3.75	30.35	22.05	3.27	2.76	3.90	4.57

Standard NPA Pendants



4 Button
PF03040105

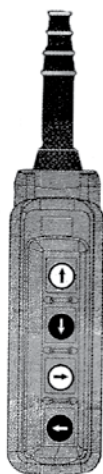

4 Button
PF03040022

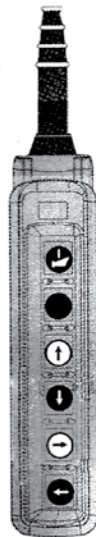

6 Button
PF03060293



8 Button
PF03080201

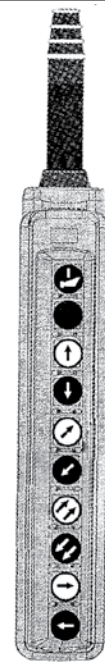

10 Button
PF03100334

- 2, 3, 12 button NPA Pendants also available
- Custom Pendants available; Part number assigned by Springer Controls.







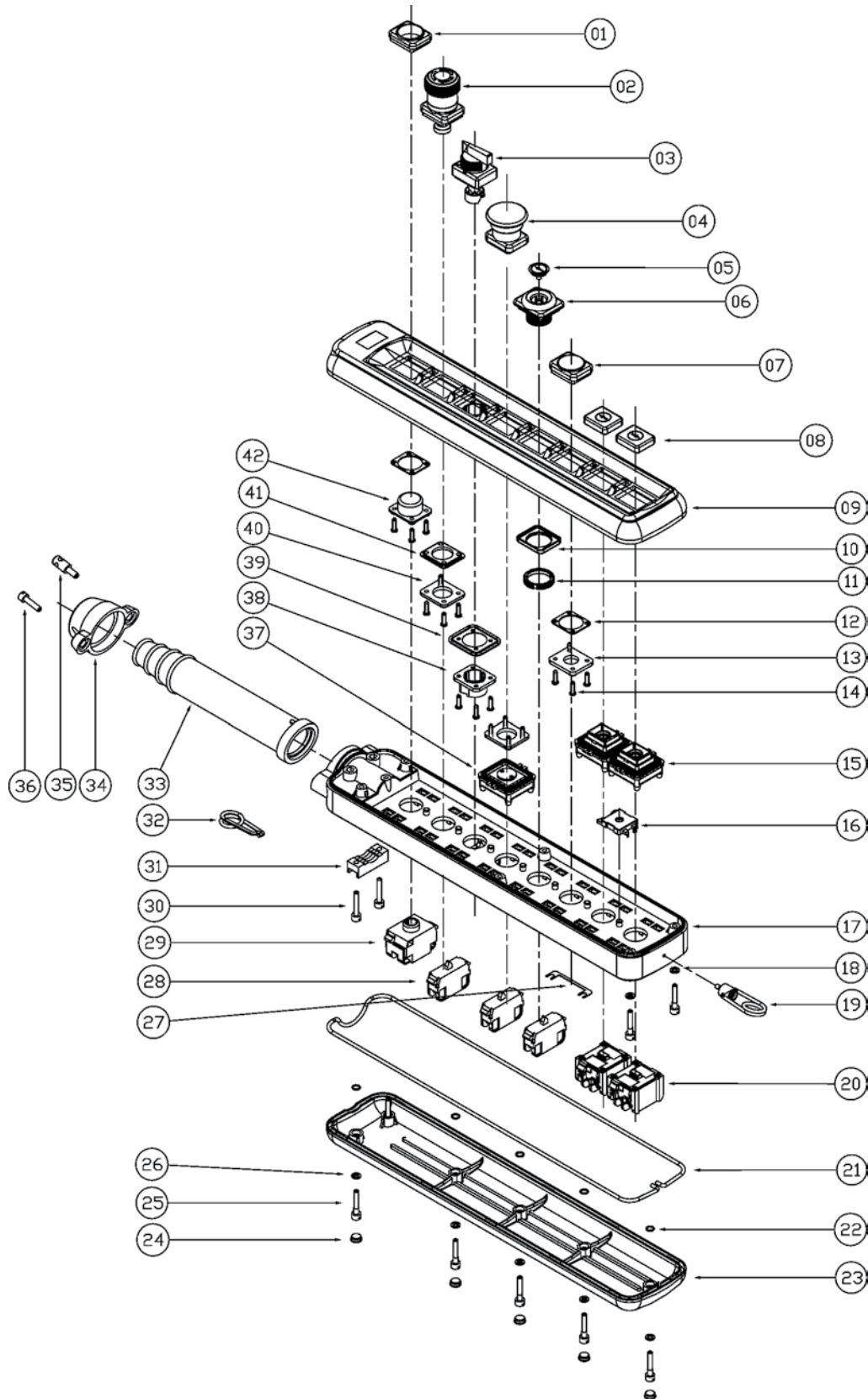







NPA PENDANT ACCESSORY PARTS

M 18

NPA Pendant - Detailed Drawing

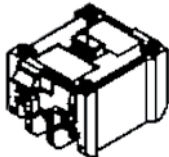

Spare Parts

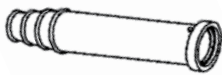
Reference	Illustration	Description	Part No.	Price
01		Red Pilot Light	PRSL0515UL	\$47.00
		Green Pilot Light	PRSL0516UL	
		Yellow Pilot Light	PRSL0521UL	
02		Emergency Stop Twist Release Mushroom Push-Button	PRSL0500UL	\$113.00
03		3 Position Key Selector Switch	PRSL0513UL	\$95.00
		3 Position Selector Switch Spring Return 3 Position Selector Switch	PRSL0514UL PRSL0519UL	\$94.00 \$94.00
04		Impulse Mushroom Push-Button	PRSL0512UL	\$92.00
		Key Mushroom Push-Button	PRSL0520UL	\$175.00
05		Disk for Dust-tight Push-Button	PRTAxxxxxx (see page M20)	\$7.00
06		Dust-tight Push-Button	PRSL0550UL	\$22.00
07		Blanking Plug	PRSL0517UL	\$32.00
08		Standard Button	PRTAxxxxxx (see page M20)	\$14.00
16		Mechanical Interlock	PRSL7816PI	\$11.00
19		Lower Hook	PRGA0051PE	\$22.00
20		1-Speed Switch - 1 N.O.+1 N.C.+1 N.O. simultaneous 2-Speed Switch - 1 N.O.+1 N.C.+1 N.O. sequenced	PRSL0504UL PRSL0505UL	\$56.00 \$81.00
		1-Speed Switch - 3 N.O. simultaneous 3-Speed Switch - 3 N.O. sequenced	PRSL0506UL PRSL0507UL	\$58.00 \$92.00
28		1 N.C. Switch	PRSL0502UL	\$27.00
		1 N.O. Switch	PRSL0503UL	\$27.00
29		Lamp Holder (full voltage)	PRSL0501UL	\$61.00
32		Upper Hook	PRGA0001PE	\$11.00
33		Cable Sleeve for 2, 6 button units	PRG00100PE	\$32.00
		Cable Sleeve for 8, 12 button units	PRG00105PE	\$40.00

Discount Schedule SC-20

NPA PENDANT - STANDARD BUTTONS

M 20

Standard Buttons

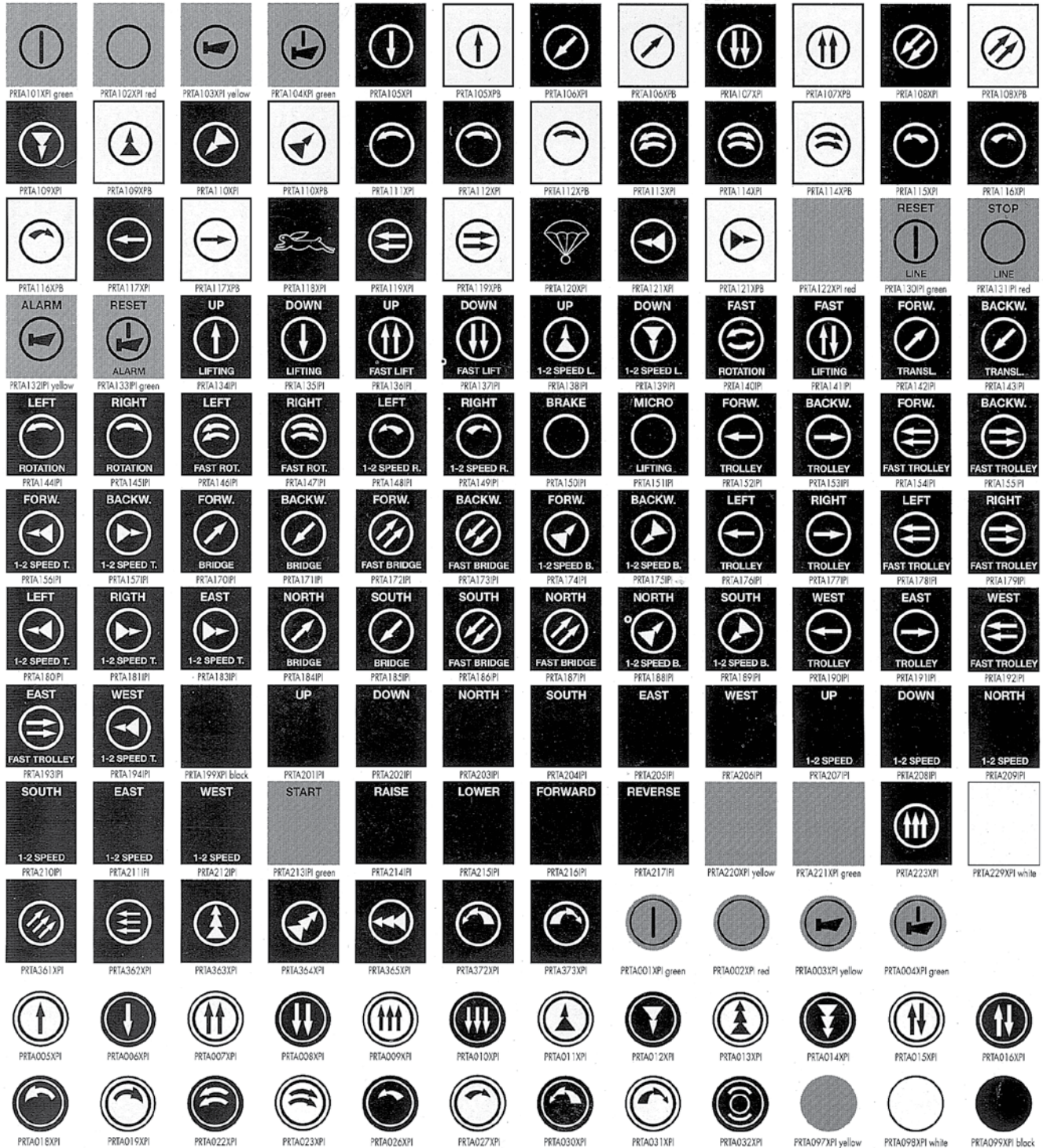

Square buttons used on standard NPA units. Round or disk style button used on "dust-tight" button (PRSL0550UL). Custom Engraving available \$20.00 each (list).



Technical Specifications

Conformity to Community Directives	73/23/CEE	93/68/CEE		
Conformity to Standards	EN 60204-1 EN 60529	EN 60947-1 EN 418	EN 60947-5-1 EN 50013	IEC 536
Ambient Temperature	Storage Operational	-40 °C / +70 °C -25 °C / +70 °C		
Protection Degree	IP 65			
Insulation Category	Class II			
Cable Entry	2 - 6 buttons; Rubber Cable Sleeve (Ø 10÷18 mm) 8 - 12 buttons; Rubber Cable Sleeve (Ø 17÷ 26 mm)			
Operating Positions	Any Position			
Weight	~ 320g			
Approvals				

Technical Specifications of Contact Switches

Utilisation Category	AC 15
Rated Operational Current	3 A
Rated Operational Voltage	250V
Rated Thermal Current	10 A
Rated Insulation Voltage	500V ~
Mechanical Life	0,5 x 10 ⁶ operations
Terminal Referencing	According to EN 50013
Connections	Screw-Type Terminals
Approvals	 

NPA PENDANT - MAINTENANCE INSTRUCTIONS

M 22

Use & Maintenance Instructions

The **NPA Pendant Control Station** is an electromechanical device for low voltage control circuits (EN 60947-1, EN60947-5-1) to be used as electrical equipment on machines (EN 60204-1) in compliance with the fundamental requirements of the Low Voltage Directive 73/23/CEE and of the Machine Directive 89/392/CEE.

The pendant station is designed for industrial use and also for use under particularly severe climactic conditions (operational temperature -25 °C to +70 °C, suitable for use in tropical environment). The equipment is not suitable for use in environments with potentially explosive atmosphere, corrosive agents or a high percentage of sodium chloride (saline fog). Oils, acids or solvents may damage the equipment.

The switches are designed for auxiliary control of contactors or electromagnetic loads (utilisation category AC-15 according to EN 60947-5-1). Do not connect more than one phase to each switch. Do not oil or grease the control elements or the switches.

The installation of the pendant station shall be carried out by an expert and trained personnel. Wiring shall be properly done according to current instructions.

Prior to installation and the maintenance of the pendant station, the main power of the machinery shall be turned off.

Steps for the proper installation of the pendant station

- remove the screws on the lower cover to open the pendant station
- cut the variable selection rubber cable sleeve and insert the cable tight enough to guarantee protection against water and/or dust.
- fix the cable to the cable sleeve using a cable tie (not supplied).
- strip the cable to a length suitable for wiring the switches
- tape the stripped part of the cable
- fix the cable inside the pendant station using the cable clamp
- connect all the switches according to the contact scheme printed on the switches (tighten the wires into the terminals with a torque equal to 0.8 Nm; insertability of wires into the switch terminals equal to 2 x 1.5mm² - 1 x 2.5mm²).
- close the pendant station checking the proper positioning of the rubber in the cover and of the "O" rings
- put the rubber caps for the screws into the holes in the lower cover.

Additional steps for mounting / replacing control / signalling bulbs into the lamp holders

- push the two clips on the sides of the lamp holder to remove it from the central part of the pendant station
- put the bayonet-type bulb into its seat (use BA9s, 125V-2.6W (max) bulbs)
- assemble the lamp holder on the central part of the pendant station checking that the two clips are properly coupled

Periodic maintenance steps

- check the proper tightening of the screws of the enclosure
- check the proper tightening of the switch terminal screws
- check all wiring (in particular where wires clamp into the switches)
- check the conditions of the rubber fit into the lower cover of the rubber of the control elements and of the cable sleeve.
- check that the plastic enclosure of the pendant station is not broken

In case any component of the pendant station is modified, the validity of the markings and the guarantee on the equipment are annulled. Should any component need replacement, use original spare parts only.

Springer Controls declines all responsibility for damages caused by the improper use or installation of the equipment.

Request Form for Non-Standard NPA Pendant Stations

Instructions:

- Fill in the **Pendant Station scheme** for the number of control elements required (2, 3, 4, 6, 8, 10 buttons)
- Write the number corresponding to the **control element** required (broken line box). When buttons are required and when necessary, mark the direction of the arrow into the corresponding circle. In case buttons different from those listed below are needed, fill in the number code required. (Button selection on page M20)
- Write the number corresponding to the **switches** required, keeping in mind that it is possible to assemble up to two switches number 2 & 3 under each control element, but only one of the other switches.
- Circle the box corresponding to the type of **buttons** required (rectangular or disks).
- Mark the rectangular box **between** the push-buttons when the mechanical interlock is required.
- Mark the appropriate box to show where the cable sleeve and the hook must be assembled (top or bottom)

Control Elements



- 29 PRSL0500UL - Emergency Stop Mushroom Pushbutton
- 30 PRSL0512UL - Impulse Mushroom Pushbutton
- 31 PRSL0513UL - 3 Position Key Selector Switch
- 32 PRSL0514UL - 3 Position Selector Switch
- 33 PRSL0515UL - Red Pilot Light

- 34 PRSL0516UL - Green Pilot Light
- 35 PRSL0517UL - Blanking Plug
- 36 PRSL0519UL - Spring Return - 3 pos. Selector Switch
- 37 PRSL0520UL - Key Mushroom Pushbutton
- 38 PRSL0521UL - Yellow Pilot Light

Switches	
1 PRSL0501UL - Lamp Holder	6 PRSL0506UL - 1 Speed 3 N.O. simultaneous
2 PRSL0502UL - 1 N.C. Switch	7 PRSL0507UL - 1 Speed 3 N.O. sequenced
3 PRSL0503UL - 1 N.O. Switch	
4 PRSL0504UL - 1 Speed 1 N.O.+1 N.C.+1 N.O. simultaneous	Buttons (circle)
5 PRSL0505UL - 2 Speed 1 N.O.+1 N.C.+1 N.O. sequenced	1 Rectangular Buttons
	2 Disks (dust-tight)

Hook	<input type="checkbox"/>	
Cable Sleeve	<input type="checkbox"/>	
Switches	<input type="checkbox"/> <input type="checkbox"/>	Control Elements
Mechanical Interlock	<input type="checkbox"/>	PRTA _____ PI
Switches	<input type="checkbox"/> <input type="checkbox"/>	Control Elements
Mechanical Interlock	<input type="checkbox"/>	PRTA _____ PI
Switches	<input type="checkbox"/> <input type="checkbox"/>	Control Elements
Mechanical Interlock	<input type="checkbox"/>	PRTA _____ PI
Switches	<input type="checkbox"/> <input type="checkbox"/>	Control Elements
Mechanical Interlock	<input type="checkbox"/>	PRTA _____ PI
Switches	<input type="checkbox"/> <input type="checkbox"/>	Control Elements
Mechanical Interlock	<input type="checkbox"/>	PRTA _____ PI
Switches	<input type="checkbox"/> <input type="checkbox"/>	Control Elements
Mechanical Interlock	<input type="checkbox"/>	PRTA _____ PI
Switches	<input type="checkbox"/> <input type="checkbox"/>	Control Elements
Mechanical Interlock	<input type="checkbox"/>	PRTA _____ PI
Switches	<input type="checkbox"/> <input type="checkbox"/>	Control Elements
Mechanical Interlock	<input type="checkbox"/>	PRTA _____ PI
Switches	<input type="checkbox"/> <input type="checkbox"/>	Control Elements
Mechanical Interlock	<input type="checkbox"/>	PRTA _____ PI
Cable Sleeve	<input type="checkbox"/>	Hook <input type="checkbox"/>

Remarks:.....

SPA PENDANT CONTROL STATION

M 24

SPA Pendant



The **SPA Series Pendant** is a rugged 2 column design with rubber bumper protection around every 4 button section. With millions in use around the world this unit has proven to be a workhorse in the environment of steel mills and heavy machinery. Available up to 20 buttons with NEMA 12 rating and 1 or 2 speed operators, selector switches and indicators.

- Rugged, Heavy-Duty Design
- 2 to 20 button, double column
- 1, 2 speed switches
- IP65 rated

SPA Pendant - Part No. & Pricing*

No. Buttons	Assembly			Standard Part No.	Price
	E-Stop	Start/Reset	1 Speed		
	1 N.C.	1 N.O.	1 N.O.		
2			2	PF02020007	\$284.00
3	1		2	PF02040185	\$500.00
4	1	1	2	PF02040241	\$500.00
6	1	1	4	PF02060355	\$663.00
8	1	1	6	PF02080237	\$798.00
10	1	1	8	PF02100324	\$912.00
12	1	1	10	PF02120306	\$1047.00

* Units 13 through 20 available along with custom units. Part numbers assigned by factory; PF02 __ J ____.
See request form on page M31.

Discount Schedule SC-20

SPA Pendant Control Station - Dimensions

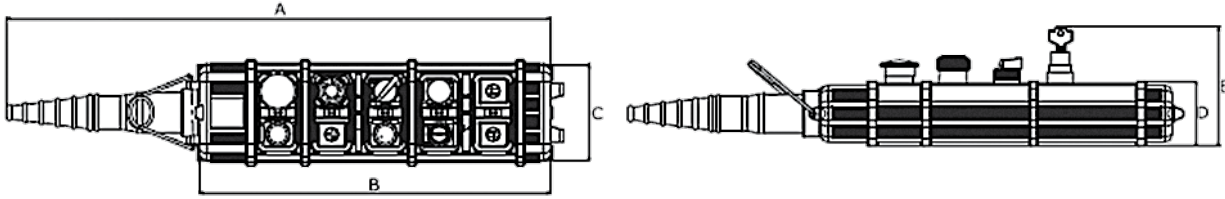

No. of Buttons	Weight (lbs)	Overall Dimensions (inches)				
		A	B	C	D	E
2	1.15	12.52	5.20	3.7	2.52	4.56
4	1.54	14.57	7.24	3.7	2.52	4.56
6	1.94	16.14	9.29	3.7	2.52	4.56
8	2.29	18.66	11.34	3.7	2.52	4.56
10	2.87	20.71	13.39	3.7	2.52	4.56
12	3.04	22.76	15.43	3.7	2.52	4.56
14	3.42	24.80	17.48	3.7	2.52	4.56
16	3.77	26.85	19.53	3.7	2.52	4.56
18	4.17	28.90	21.57	3.7	2.52	4.56
20	4.52	30.95	23.62	3.7	2.52	4.56

Standard SPA Pendants



4 Button
PF02040241



6 Button
PF02060355



8 Button
PF02080237



10 Button
PF02100324

- 2, 3, 12 button standard units available
- 12 - 20 button pendants and custom pendants available - see page M31







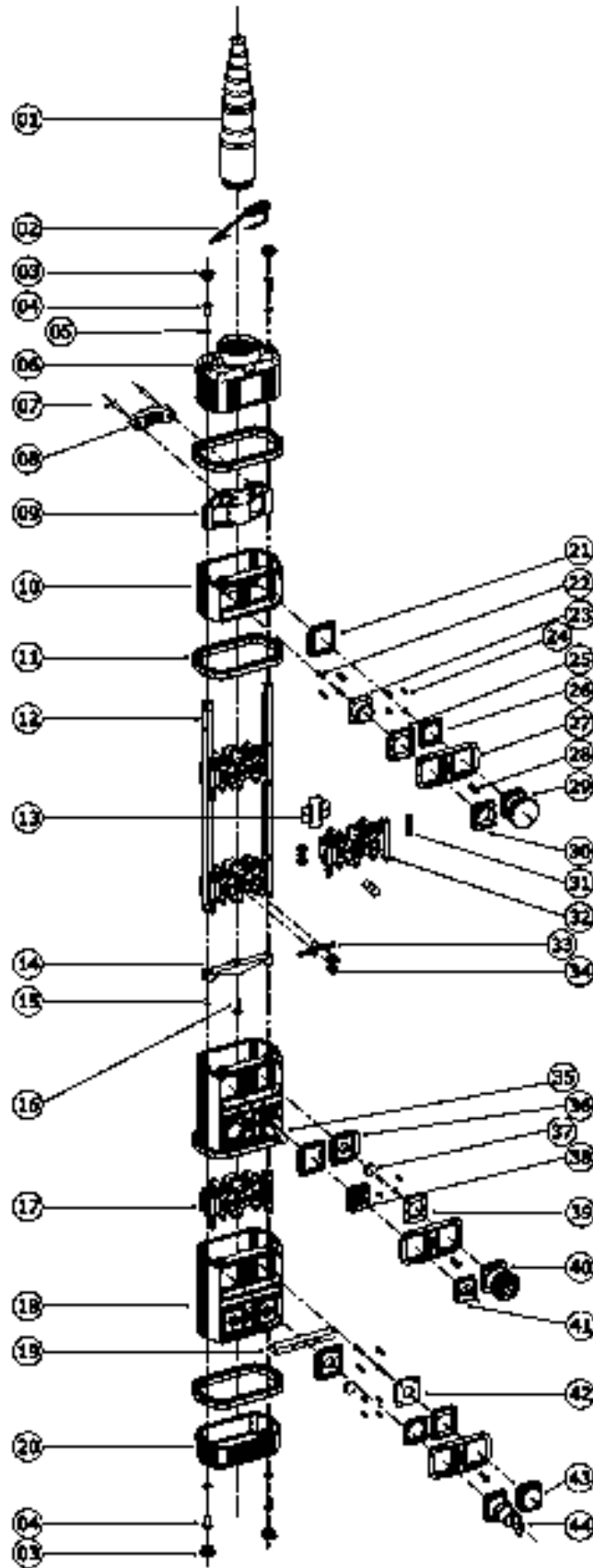

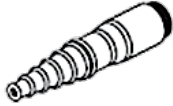

SPA PENDANT - ACCESSORY PARTS

M 26

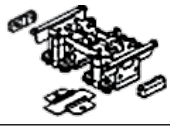
SPA Pendant - Detailed Drawing



Spare Parts

Reference	Illustration	Description	Part No.	Price
01		Cable Sleeve	PRSL0146PE	\$68.00
02		Hook	PRGA0012PE	\$5.50
17		1 N.O. + 1 N.C. / 1 N.O. + 1 N.C. Switch 2 N.O. + 1 N.C. / 2 N.O. + 1 N.C. Switch 1 N.O. + 1 N.C. / 2 N.O. + 2 N.C. Switch 2 N.O. + 2 N.C. / 2 N.O. + 2 N.C. Switch	PRSL0074XX PRSL0075XX PRSL0076XX PRSL0077XX	\$95.00 \$139.00 \$153.00 \$180.00
23		Red Pilot Light Green Pilot Light Yellow Pilot Light	PRSL3534UL PRSL3535UL PRSL3542UL	\$47.00 \$47.00 \$47.00
29		Impulse Mushroom Push-Button	PRSL3531PI	\$56.00
32		1 N.O. + 1 N>C. Switch / Lamp Holder	PRSL0073XX	\$139.00
35		2 Position Selector Switch 3 Position Selector Switch	PRSL3540PI PRSL3543PI	\$52.00 \$72.00
40		Emergency Stop Mushroom Push-Button	PRSL3500PI	\$113.00
41		Button	PRTAXXXXXX (see page M30)	\$14.00
43		Blanking Plug	PRSL0517UL	\$32.00
44		2 Position Key Selector Switch	PRSL3539PI	\$133.00

SPA PENDANT - STANDARD BUTTONS

M 28

Standard Buttons

Custom Engraving available - consult factory \$20.00 each (list).

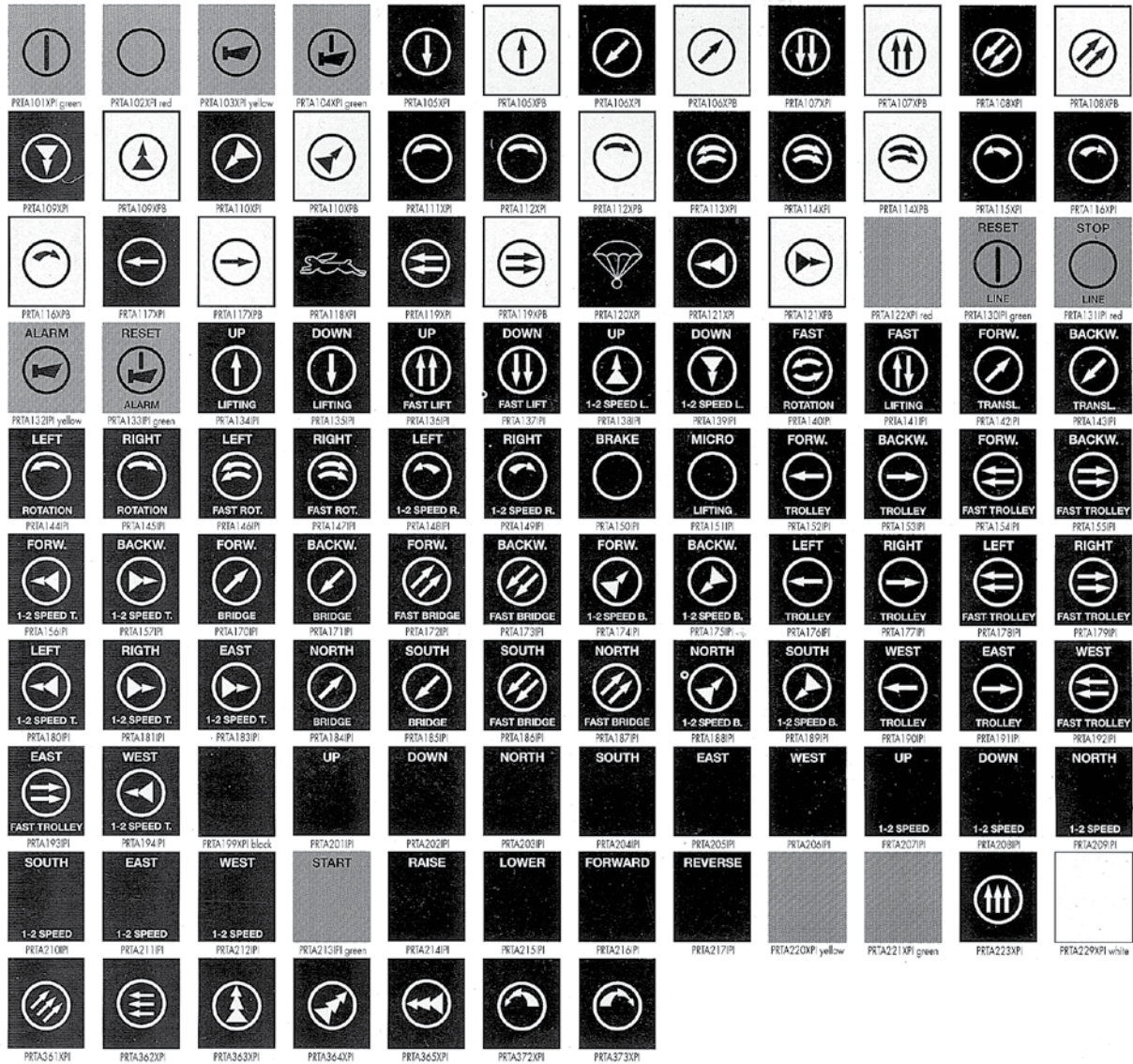

SPA PENDANT CONTROL STATION - TECHNICAL SPECIFICATIONS

Technical Specifications

Conformity to Community Directives	73/23/CEE	93/68/CEE		
Conformity to Standards	EN 60204-1 EN 60529	EN 60947-1 EN 418	EN 60947-5-1 EN 50013	IEC 536
Ambient Temperature	Storage Operational	-40° C / +70° C -25° C / +70° C		
Protection Degree	IP 65			
Insulation Category	Class II			
Cable Entry	Rubber Cable Sleeve (Ø 14+ 26 mm)			
Operating Positions	Any Position			
Approvals	CE			

Technical Specifications of Contact Switches

Utilisation Category	AC 15
Rated Operational Current	1.9 A
Rated Operational Voltage	380V
Rated Thermal Current	10 A
Rated Insulation Voltage	500V ~
Mechanical Life	1 x 10 ⁶ operations
Terminal Referencing	According to EN 50013
Connections	Screw-Type Terminals
Approvals	CE cUL_{us}

SPA PENDANT - MAINTENANCE INSTRUCTIONS

M 30

Use & Maintenance Instructions

The **SPA Pendant Control Station** is an electromechanical device for low voltage control circuits (EN 60947-1, EN60947-5-1) to be used as electrical equipment on machines (EN 60204-1) in compliance with the fundamental requirements of the Low Voltage Directive 73/23/CEE and of the Machine Directive 89/392/CEE.

The pendant station is designed for industrial use and also for use under particularly severe climactic conditions (operational temperature -25 °C to +70 °C, suitable for use in tropical environment). The equipment is not suitable for use in environments with potentially explosive atmosphere, corrosive agents or a high percentage of sodium chloride (saline fog). Oils, acids or solvents may damage the equipment.

The switches (17, 32) are designed for auxiliary control of contactors or electromagnetic loads (utilisation category AC-15 according to EN 60947-5-1). Do not connect more than one phase to each switch (17, 32). Do not oil or grease the control elements (29, 35, 40, 41, 44) or the switches (17, 32).

The installation of the pendant station shall be carried out by an expert and trained personnel. Wiring shall be properly done according to current instructions.

Prior to installation and the maintenance of the pendant station, the main power of the machinery shall be turned off.

Steps for the proper installation of the pendant station

- remove the plastic plugs (03) from the lower cover (20)
- remove the screws (04) from the lower cover (20)
- remove the lower cover (20), the rubber frames (11) and the sections (10, 18) from the inner part of the pendant station; make sure to follow the same sequence when reassembling the sections (10, 18)
- remove the plastic plugs (03) from the upper cover (06)
- remove the screws (04) from the upper cover (06) and the latter from the inner part of the pendant station
- screw the variable section rubber cable sleeve (01) on the upper cover (06)
- cut the variable section rubber cable sleeve (33) and insert the cable tight enough to guarantee protection against water and/or dust
- strip the cable to a length suitable for wiring the switches (17, 32)
- tape the stripped part of the cable
- fix the cable inside the pendant station using the cable clamp (07, 08)
- connect all the switches (17, 32) (tighten the wires into the terminals with a torque equal to 0.8 Nm; insertability of wires into the switch terminals equal to 2 x 1.5mm² - 1 x 2.5mm²); for the correct positioning of the wires into the pendant station, remove the wire covers (13) from the switches (17,32), place the wires into the seats and fix the wire covers again (13)
- mount the upper cover (06), make sure that the writing "TER" and the label identifying the product are on the same side of the actuators (29, 35, 40, 41, 44)
- screw the plastic plugs (03) on the lower cover (20)
- assemble the hook (02)

Additional steps for replacing the switches

- open the pendant station as explained in the installation steps
- remove possible wires from the switch (17, 32) needing replacement loosen the screw (16) on the bottom of the inner part of the pendant station
- remove the two plastic guides (31) from the switch (17, 32) and remove the latter from the pendant station
- remove the two plastic guides (31) from the new switch (17, 32)
- place the switch (17, 32) on the inner part of the pendant station
- place back the two plastic guides (31) checking that they are on the right side (the slightly raised part of the guides must be in touch with the metal rods (12) of the pendant station)
- tighten the screw (16) on the bottom of the inner part of the pendant station in order to fix the switches (17, 32)
- wire back the switch and close the pendant station as explained in the installation steps

Periodic maintenance steps

- check the proper tightening of the screws (04, 28)
- check the proper tightening of the switch (17, 32) terminal screws
- check all wiring (in particular where wires clamp into the switches)
- check the conditions of the rubber frames (11) of the rubber of the actuators (21, 25, 36) and of the cable sleeve (01)
- check that the plastic enclosure (06, 10, 18, 20) of the pendant station is not broken

In case any component of the pendant station is modified, the validity of the markings and the guarantee on the equipment are annulled. Should any component need replacement, use original spare parts only.

Springer Controls declines all responsibility for damages caused by the improper use or installation of the equipment.

SPA PENDANT CONTROL STATION

M31

Request Form for Non-Standard SPA Pendant Stations

Instructions:

- Fill in the **Pendant Station** scheme for the number of control elements required (2, 3, 4, 6, 8, 10, 12, 14, 16, 18 or 20 buttons).
- Write the number corresponding to the **control element** required (broken line box). When buttons are required, fill in the PRTA____ code and when necessary, mark the direction of the arrow into the corresponding box.
- Write the number corresponding to the **switches** required. When PRSL0076xx is required, mark the position of the 2 N.O. + 2 N.C. contacts (left or right).
- Mark the box corresponding to the mechanical interlock when required.
- Mark the appropriate box to show where the cable sleeve and the hook must be assembled (top or bottom).

Control Elements

- | | |
|---|---|
| 1 | PRSL3500PI - Emergency Stop Mushroom Pushbutton |
| 2 | PRSL3531PI - Impulse Mushroom Pushbutton |
| 3 | PRSL3539PI - 2 Position Key Selector Switch |
| 4 | PRSL3540PI - 2 Position Selector Switch |
| 5 | PRSL3543PI - 3 Position Selector Switch |
| 6 | PRSL3534UL - Red Pilot Light |
| 7 | PRSL3535UL - Green Pilot Light |
| 8 | PRSL3542UL - Yellow Pilot Light |
| 9 | PRSL0517UL - Blanking Plug |

Switches

- | | |
|---|--|
| 1 | PRSL0073XX - 1 N.O. + 1 N.C. / Lamp Holder |
| 2 | PRSL0074XX - 1 N.O. + 1 N.C. / 1 N.O. + 1 N.C. |
| 3 | PRSL0075XX - 2 N.O. + 1 N.C. / 2 N.O. + 1 N.C. |
| 4 | PRSL0076XX - 1 N.O. + 1 N.C. / 2 N.O. + 2 N.C. |
| 5 | PRSL0077XX - 2 N.O. + 2 N.C. / 2 N.O. + 2 N.C. |

Remarks:.....

	Hook	<input type="checkbox"/>		
	Cable Sleeve	<input type="checkbox"/>		
<input type="checkbox"/>	<input type="checkbox"/>	Switch	<input type="checkbox"/>	Mechanical Interlock
	<input type="checkbox"/>		<input type="checkbox"/>	
	PRTA		PRTA	
<input type="checkbox"/>	<input type="checkbox"/>	Switch	<input type="checkbox"/>	Mechanical Interlock
	<input type="checkbox"/>		<input type="checkbox"/>	
	PRTA		PRTA	
<input type="checkbox"/>	<input type="checkbox"/>	Switch	<input type="checkbox"/>	Mechanical Interlock
	<input type="checkbox"/>		<input type="checkbox"/>	
	PRTA		PRTA	
<input type="checkbox"/>	<input type="checkbox"/>	Switch	<input type="checkbox"/>	Mechanical Interlock
	<input type="checkbox"/>		<input type="checkbox"/>	
	PRTA		PRTA	
<input type="checkbox"/>	<input type="checkbox"/>	Switch	<input type="checkbox"/>	Mechanical Interlock
	<input type="checkbox"/>		<input type="checkbox"/>	
	PRTA		PRTA	
<input type="checkbox"/>	<input type="checkbox"/>	Switch	<input type="checkbox"/>	Mechanical Interlock
	<input type="checkbox"/>		<input type="checkbox"/>	
	PRTA		PRTA	
<input type="checkbox"/>	<input type="checkbox"/>	Switch	<input type="checkbox"/>	Mechanical Interlock
	<input type="checkbox"/>		<input type="checkbox"/>	
	PRTA		PRTA	
<input type="checkbox"/>	<input type="checkbox"/>	Switch	<input type="checkbox"/>	Mechanical Interlock
	<input type="checkbox"/>		<input type="checkbox"/>	
	PRTA		PRTA	
	Cable Sleeve	<input type="checkbox"/>	Hook	<input type="checkbox"/>

NOTES

M 32

ROTARY GEAR LIMIT SWITCHES

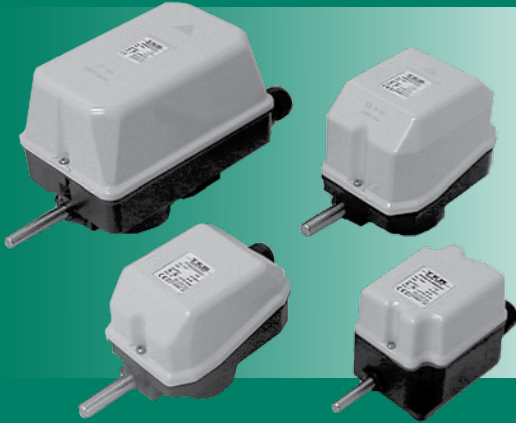

SPRINGER
controls company

Index
N

Springer Controls offers a complete line of the T.E.R. (Tecno Elettrica Ravasi) Rotary Gear Limit Switches with ratios from 1:1 to 1:9,400. Outputs with 2 to 12 switches along with optimal potentiometer outputs. All units are manufactured by Tecno Elettrica Ravasi to ISO 9001 standards and are UL and c-UL approved. Some applications include but are not limited to; overhead doors, overhead crane applications, boat hoists, and theatrical stage applications. **Springer Controls** can customize all model types, along with gear ratios, to meet your application.

ROTARY GEAR LIMIT SWITCHES

Model/Types & General Operation.....	N2, N3
MF2C Part No. - Pricing, Request Form.....	N4, N5
PF2C Part No. - Pricing, Request Form.....	N6, N7
GF4C Part No. - Pricing, Request Form.....	N8, N9
SF12C Part No. - Pricing, Request Form.....	N10, N11
Accessory Parts & Specifications.....	N12
Dimensions.....	N13, N14

ROTARY GEAR LIMIT SWITCHES - MODEL TYPES & GENERAL OPERATION

N₂

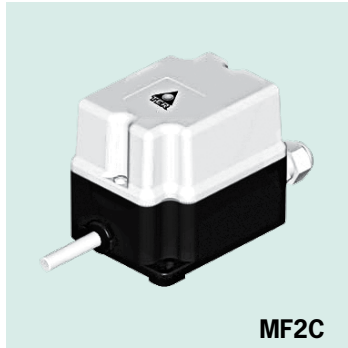

MF2C

- 1:15 to 1:150 speed ratio, 2 or 3 micro-switches (2 standard), snap action
- 600 Maximum RPM
- Smallest RGLS; Weight .6 lbs
- IP65 rated

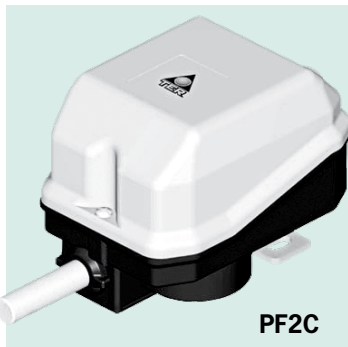

PF2C

- 1:1 to 1:295 speed ratio, 2 micro-switches, snap action or slow break
- 1 potentiometer in place of micro-switches.
- 1200 Maximum RPM
- Weight 1.2 lbs
- IP65 rated



GF4C

- 1:1 to 1:900 speed ratio, 1 to 6 micro-switches (4 standard), snap action or slow break
- 1 potentiometer in place of micro-switch
- 1800 Maximum RPM
- Weight 1.6 lbs
- IP65 rated

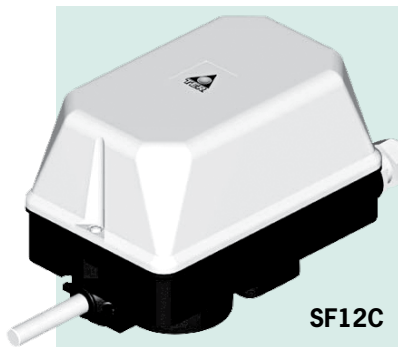

SF12C

- 1:1 to 1:9400 speed ratio, 12 micro-switches, snap action or slow break
- 2 potentiometer in addition to 4 micro-switches
- 1800 Maximum RPM
- Weight 1.6 lbs
- IP65 rated

ROTARY GEAR LIMIT SWITCHES - GENERAL OPERATION

N3

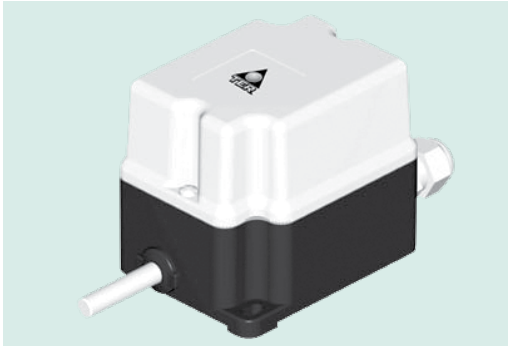

The rotary limit switch is used to control the movement of industrial machinery. It operates as an auxiliary controller of electrical motors through a power interface, such as a contactor or PLC. Suitable for heavy duty, its shaft is connected to the motor and, after a set number of revolutions, the cams operate the switches, thus starting the predetermined movement.

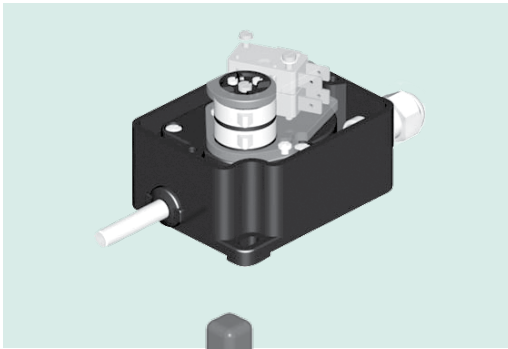

Revolution ratios ranging from 1:1 to 1:9400 results from the use of different combinations of gear wheels between the input shaft and the output shaft, which is connected to the cams operating the micro-switches. The cam-switch sets can be substituted for potentiometers suitable for the connection of electronic equipment.

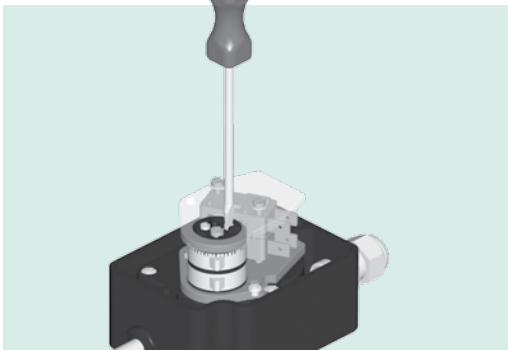

Each cam can be set with great accuracy using the cam adjusting screws. The micro-switches are of a positive opening type, thus suitable for safety functions. It is available with direct control switches for operating directly on the motor. Materials and components are wear resistant and protect the equipment against water and dust.

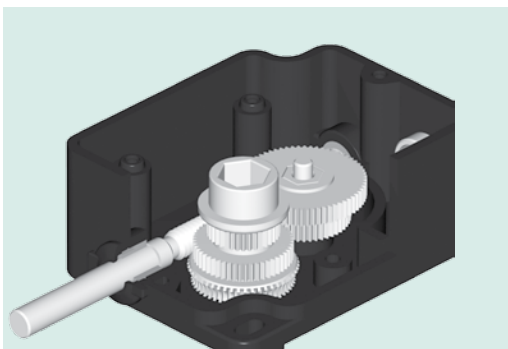

The part number listed for each model type utilize the standard, or most common ratio's. Any ratio can be requested, and a custom part # given, at no extra cost.

MF2C ROTARY LIMIT SWITCH

N4

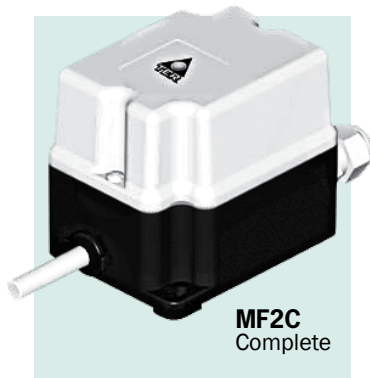

MF2C Standard Pricing

Type	# of Switches	Price
MF2C	2	\$253.00
	3	\$307.00

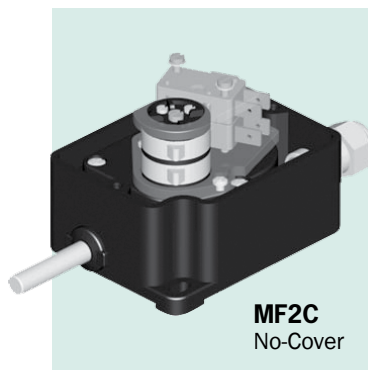

MF2C General Information



- 1:15 to 1:150 speed ratio, 2 or 3 micro-switches, snap action
- IP65 rated
- 600 Maximum RPM
- 8mm shaft standard
- Smallest RGLS; Weight .6 lbs
- UL approved
- 3 amp rated operating current

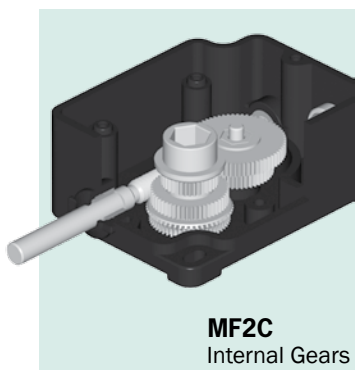

MF2C Standard Units Part Number*

Revolution Ratio	2 Switches	3 Switches
1:15	F5901 0015 0003	F5901 0015 0004
1:25	F5901 0025 0005	F5901 0025 0006
1:50	F5901 0050 0005	F5901 0050 0012
1:75	F5901 0075 0004	F5901 0075 0005
1:100	F5901 0100 0005	F5901 0100 0007
1:150	F5901 0150 0003	F5901 0150 0004

Standard limit switches are equipped with 2 or 3 snap-action switches and with pointed cams (PRSL7140PI). Maximum revolution ratio 1:150.

* Other assemblies and revolution ratios are available upon request. See MF2C request form on page N5. See page N13 for dimensional specifications.





Discount Schedule SC-20

REQUEST FORM FOR NON-STANDARD MF2C LIMIT SWITCHES

Instructions

- Write the number corresponding to the **cams** and to the **pinion gear** required
- Write the **revolution ratio** required
- Mark the boxes corresponding to the components required

CAMS

- | | | |
|--------------------------|---|------------|
| <input type="checkbox"/> |  | PRSL7140PI |
| <input type="checkbox"/> |  | PRSL7141PI |
| <input type="checkbox"/> |  | PRSL7142PI |
| <input type="checkbox"/> |  | PRSL7143PI |
| <input type="checkbox"/> |  | PRSL7144PI |

CAMS

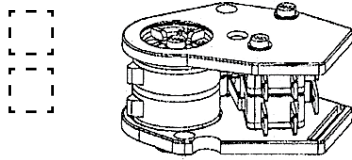

OR

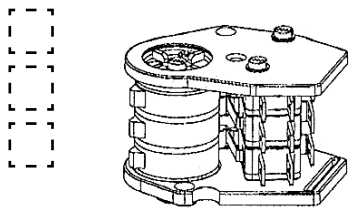

PINION GEARS

- | | | |
|--------------------------|------------|---------|
| <input type="checkbox"/> | PRSL0911PI | M10 Z12 |
| <input type="checkbox"/> | PRSL0912PI | M12 Z10 |
| <input type="checkbox"/> | PRSL0913PI | M14 Z10 |
| <input type="checkbox"/> | PRSL0914PI | M16 Z10 |
| <input type="checkbox"/> | PRSL0915PI | M20 Z8 |
| <input type="checkbox"/> | PRSL0916PI | M5 Z12 |
| <input type="checkbox"/> | PRSL0917PI | M6 Z11 |
| <input type="checkbox"/> | PRSL0918PI | M8 Z12 |
| <input type="checkbox"/> | PRSL0944PI | M12 Z12 |

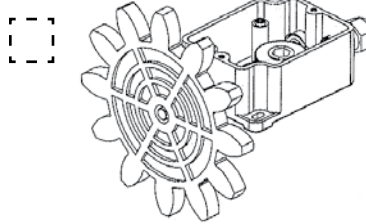

REVOLUTION RATIO

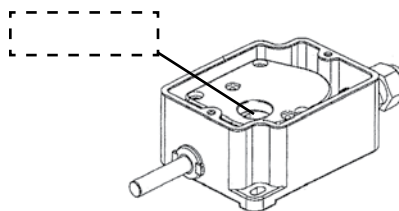

COVER

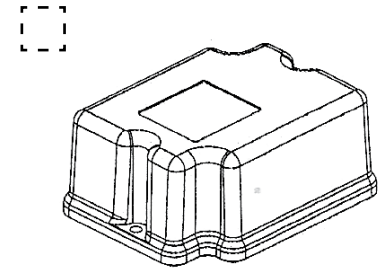

STANDARD SHAFT

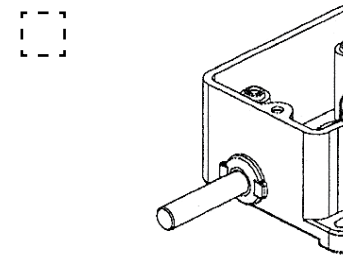

FLEXIBLE SHAFT

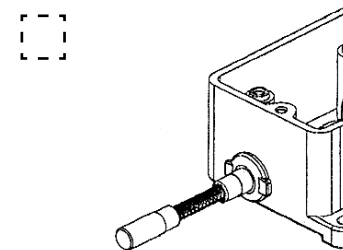

Remarks:.....

.....

.....

.....

.....

.....

.....

.....

.....

.....

.....

PF2C ROTARY LIMIT SWITCH

N6

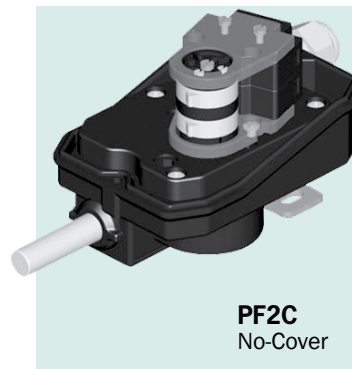
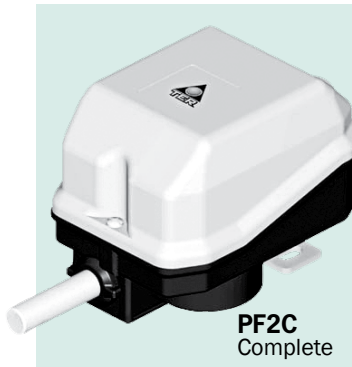

PF2C Standard Pricing

Type	Revolution Ratio	Price
PF2C	1:1 thru 1:19	\$520.00
	1:20 thru 1:295	\$460.00

PF2C General Information



- 1:1 to 1:295 speed ratio, 2 micro-switches (snap action or slow break)
- Optional potentiometer
- IP65 rated
- 1200 Maximum RPM
- 12mm input shaft
- Weight 1.2 lbs
- UL approved
- 3 amp rated operating current

PF2C Standard Units Part Number*

Revolution Ratio	Type of Contact	2 Switches
1:10	Snap	F5902 0010 0001
	Slow	F5902 0010 0004
1;15	Snap	F5902 0015 0001
	Slow	F5902 0015 0003
1;20	Snap	F5902 0020 0002
	Slow	F5902 0020 0008
1;25	Snap	F5902 0025 0001
	Slow	F5902 0025 0003
1;50	Snap	F5902 0050 0001
	Slow	F5902 0050 0006
1;75	Snap	F5902 0075 0001
	Slow	F5902 0075 0003
1;100	Snap	F5902 0100 0001
	Slow	F5902 0100 0002
1;150	Snap	F5902 0150 0001
	Slow	F5902 0150 0002
1;200	Snap	F5902 0200 0001
	Slow	F5902 0200 0002
1;250	Snap	F5902 0250 0002
	Slow	F5902 0250 0003

*Standard limit switches are equipped with 2 snap or slow action switches and with pointed cams (PRSL714OPI). Other assemblies and revolution ratios are available upon request. See PF2C request form on page N7. See page N13 for dimensional specifications.

Discount Schedule SC-20





REQUEST FORM FOR NON-STANDARD PF2C LIMIT SWITCHES

N7

Instructions

- Write the number corresponding to the **cams**, the **switches**, the **pinion gear** and **potentiometers** required
- When a potentiometer is required, mark the box corresponding to the type of **coupling** needed
- Write the **revolution ratio** required
- Mark the boxes corresponding to the components required.

CAMS

- | | | |
|--------------------------|---|------------|
| <input type="checkbox"/> |  | PRSL7140PI |
| <input type="checkbox"/> |  | PRSL7141PI |
| <input type="checkbox"/> |  | PRSL7142PI |
| <input type="checkbox"/> |  | PRSL7143PI |
| <input type="checkbox"/> |  | PRSL7144PI |

SWITCHES

- | | | |
|--------------------------|------------|-------------|
| <input type="checkbox"/> | PRSL0036XX | Snap Action |
| <input type="checkbox"/> | PRSL0037XX | Slow Action |

CAMS

SWITCHES

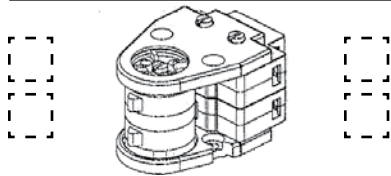

PINION GEARS

- | | | |
|--------------------------|------------|---------|
| <input type="checkbox"/> | PRSL0911PI | M10 Z12 |
| <input type="checkbox"/> | PRSL0912PI | M12 Z10 |
| <input type="checkbox"/> | PRSL0913PI | M14 Z10 |
| <input type="checkbox"/> | PRSL0914PI | M16 Z10 |
| <input type="checkbox"/> | PRSL0915PI | M20 Z8 |
| <input type="checkbox"/> | PRSL0916PI | M5 Z12 |
| <input type="checkbox"/> | PRSL0917PI | M6 Z11 |
| <input type="checkbox"/> | PRSL0918PI | M8 Z12 |
| <input type="checkbox"/> | PRSL0944PI | M12 Z12 |

PINION GEAR

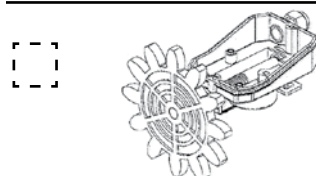

POTENTIOMETERS

- | | |
|--------------------------|---|
| <input type="checkbox"/> | PRVV9020PE
Megatron 4.7 k
continuous rotation |
| <input type="checkbox"/> | PRVV9025PE
Megatron 10 k
continuous rotation |
| <input type="checkbox"/> | PRVV9035PE
Megatron 2.2 k
continuous rotation |
| <input type="checkbox"/> | PRVV9030PE
MCB 10 k (320° thread) |
| <input type="checkbox"/> | PRVV9031PE
MCB 10 k
continuous rotation |



O-RING COUPLING

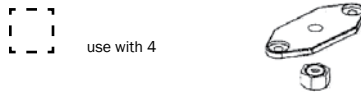

FIXED COUPLING

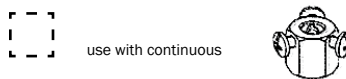

REVOLUTION RATIO

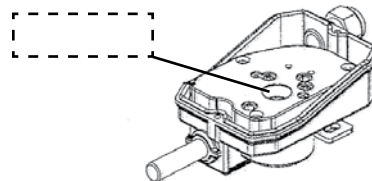

Remarks:.....

.....

.....

.....

.....

.....

COVER

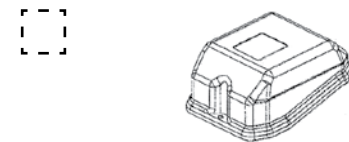

STANDARD SHAFT

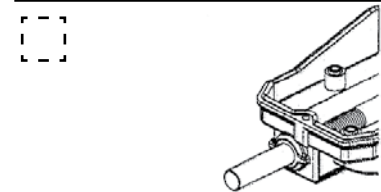

FLEXIBLE SHAFT

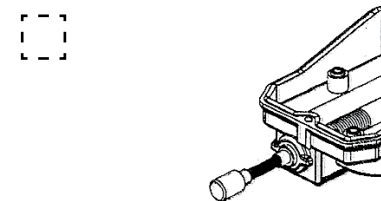

MALE COUPLING



FEMALE COUPLING



FLANGE

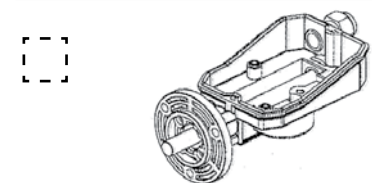

GF4C ROTARY LIMIT SWITCH



N8

GF4C Standard Pricing

Type	Revolution Ratio	2 Switch Price	3 Switch Price	4 Switch Price
GF4C	1:1 thru 1:20	\$614.00	\$713.00	\$813.00
	1:25 thru 1:960	\$533.00	\$623.00	\$722.00

GF4C General Information



- 1:1 to 1:960 speed ratio, 4 micro-switches (snap action or slow break)
- Optional potentiometer
- IP65 rated
- 1800 Maximum RPM
- 12mm input shaft
- Weight 1.2 lbs
- UL approved
- 3 amp rated operating current

GF4C Standard Units Part Number*

Revolution Ratio	Type of Contact	2 Switches	3 Switches	4 Switches
1:1	Snap	F5903 0001 0003	F5903 0001 0002	F5903 0001 0001
	Slow	F5903 0001 0004	F5903 0001 0005	F5903 0001 0006
1:5	Snap	F5903 0005 0002	F5903 0005 0003	F5903 0005 0001
	Slow	F5903 0005 0004	F5903 0005 0005	F5903 0005 0006
1:10	Snap	F5903 0010 0003	F5903 0010 0004	F5903 0010 0002
	Slow	F5903 0010 0005	F5903 0010 0006	F5903 0010 0007
1:15	Snap	F5903 0015 0004	F5903 0015 0003	F5903 0015 0002
	Slow	F5903 0015 0007	F5903 0015 0008	F5903 0015 0001
1:20	Snap	F5903 0020 0002	F5903 0020 0003	F5903 0020 0001
	Slow	F5903 0020 0004	F5903 0020 0005	F5903 0020 0006
1:25	Snap	F5903 0025 0006	F5903 0025 0003	F5903 0025 0001
	Slow	F5903 0025 0007	F5903 0025 0008	F5903 0025 0002
1:50	Snap	F5903 0050 0002	F5903 0050 0003	F5903 0050 0006
	Slow	F5903 0050 0028	F5903 0050 0017	F5903 0050 0007
1:75	Snap	F5903 0075 0007	F5903 0075 0008	F5903 0075 0004
	Slow	F5903 0075 0009	F5903 0075 0010	F5903 0075 0006
1:100	Snap	F5903 0100 0002	F5903 0100 0004	F5903 0100 0003
	Slow	F5903 0100 0001	F5903 0100 0013	F5903 0100 0004
1:150	Snap	F5903 0100 0002	F5903 0150 0011	F5903 0150 0008
	Slow	F5903 0150 0001	F5903 0150 0009	F5903 0150 0003
1:200	Snap	F5903 0200 0006	F5903 0200 0002	F5903 0200 0003
	Slow	F5903 0200 0007	F5903 0200 0004	F5903 0200 0008
1:250	Snap	F5903 0250 0003	F5903 0250 0007	F5903 0250 0008
	Slow	F5903 0250 0009	F5903 0250 0010	F5903 0250 0011
1:300	Snap	F5903 0300 0004	F5903 0300 0006	F5903 0300 0007
	Slow	F5903 0300 0008	F5903 0300 0009	F5903 0300 0010

*Standard limit switches are equipped with 2, 3 or 4 snap or slow action switches and with pointed cams (PRSL7140PI). Other assemblies and revolution ratios are available upon request. See GF4C request form on page N9. It is possible to assemble up to 6 switches. Maximum ratio 1:960. See page N13 for dimensional specifications.

Discount Schedule SC-20





REQUEST FORM FOR NON-STANDARD GF4C LIMIT SWITCHES

N₉

Instructions

- Write the number corresponding to the **components** required
- Write the numbers corresponding to the **cams**, the **switches**, the **pinion gear** and the **potentiometers** required
- When a potentiometer is required, mark the box corresponding to the type of **coupling** needed
- Write the **revolution ratio** required for each output

CAMS

1		PRSL7140PI
2		PRSL7141PI
3		PRSL7142PI
4		PRSL7143PI
5		PRSL7144PI

SWITCHES

1	PRSL0036XX	Snap Action
2	PRSL0037XX	Slow Action

POTENTIOMETERS

1	PRVV9020PE	Megatron 4.7 k continuous rotation
2	PRVV9025PE	Megatron 10 k continuous rotation
3	PRVV9035PE	Megatron 2.2 k continuous rotation
4	PRVV9030PE	MCB 10 k
5	PRVV9031PE	MCB 10 k continuous rotation

MALE COUPLING

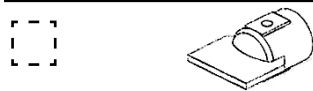

FEMALE COUPLING



FLANGE

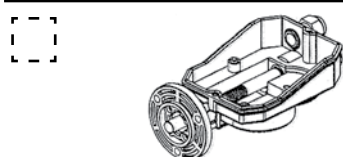

POTENTIOMETERS

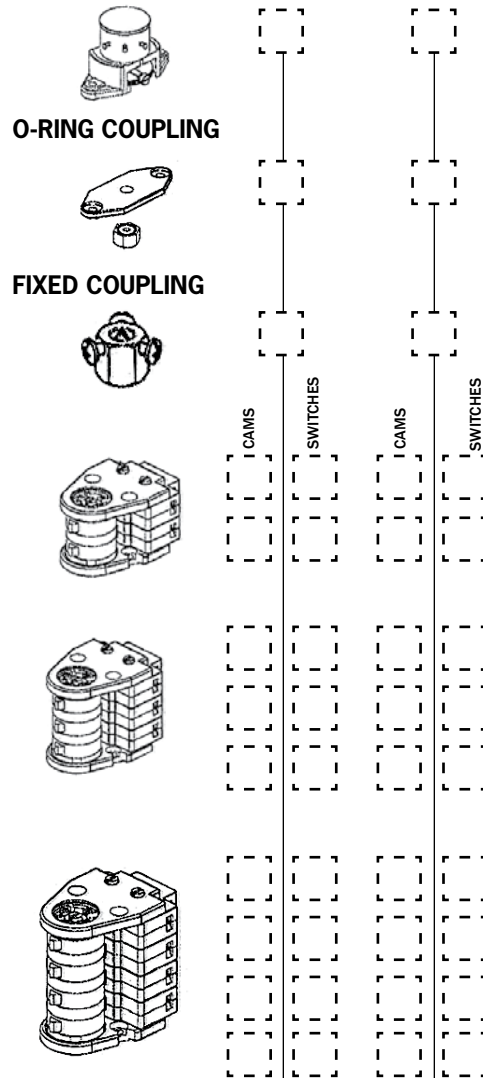

REVOLUTION RATIO

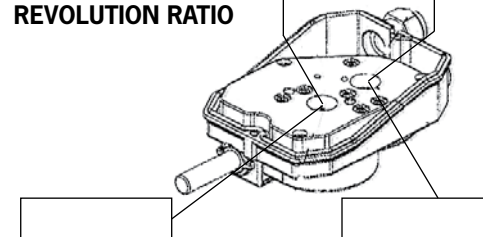

COVER



STANDARD SHAFT



FLEXIBLE SHAFT



PINION GEARS

1	PRSL0911PI	M10 Z12
2	PRSL0912PI	M12 Z10
3	PRSL0913PI	M14 Z10
4	PRSL0914PI	M16 Z10
5	PRSL0915PI	M20 Z8
6	PRSL0916PI	M5 Z12
7	PRSL0917PI	M6 Z11
8	PRSL0918PI	M8 Z12
9	PRSL0944PI	M12 Z12

PINION GEAR

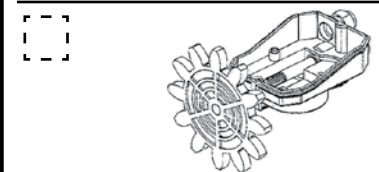

Remarks:.....

SF12C ROTARY LIMIT SWITCH

SF12C Standard Pricing

Type	Revolution Ratio	2 Switch Price	3 Switch Price	4 Switch Price	6 Switch Price	8 Switch Price	10 Switch Price	12 Switch Price
SF12C	1:1 thru 1:15	\$1044	\$1152	\$1255	\$1539	\$1734	\$2025	\$2223
	1:16 thru 1:24	\$1015	\$1127	\$1235	\$1512	\$1716	\$2005	\$2203
	1:25 thru 1:2700	\$912	\$1015	\$1127	\$1411	\$1620	\$1900	\$2113
	1:2750 thru 1:9400	\$1029	\$1129	\$1237	\$1512	\$1716	---	---

N10



SF12C General Information



- 1:1 to 1:9400 speed ratio, 12 micro-switches (snap action or slow break)
- Optional potentiometer (2 total)
- IP65 rated
- 1800 Maximum RPM
- 12mm input shaft
- Weight 3.4 lbs
- 3 amp rated operating current

SF12C Standard Units Part Number*

Revolution Ratio	Type of Contact	2 Switches	3 Switches	4 Switches	6 Switches	8 Switches	10 Switches	12 Switches
1:1	Snap	F5904 0001 0001	F5904 0001 0002	F5904 0001 0003	F5904 0001 0004	F5904 0001 0005	F5904 0001 0006	F5904 0001 0007
	Slow	F5904 0001 0008	F5904 0001 0009	F5904 0001 0010	F5904 0001 0011	F5904 0001 0012	F5904 0001 0013	F5904 0001 0014
1:5	Snap	F5904 0005 0004	F5904 0005 0005	F5904 0005 0003	F5904 0005 0006	F59040005 0007	F5904 0005 0008	F5904 0005 0009
	Slow	F5904 0005 0010	F5904 0005 0011	F5904 0005 0012	F5904 0005 0013	F5904 0005 0014	F5904 0005 0015	F5904 0005 0016
1:10	Snap	F5904 0010 0002	F5904 0010 0003	F5904 0010 0004	F5904 0010 0005	F5904 0010 0006	F5904 0010 0007	F5904 0010 0008
	Slow	F5904 0010 0009	F5904 0010 0010	F5904 0010 0011	F5904 0010 0012	F5904 0010 0013	F59040010 0014	F5904 0010 0015
1:15	Snap	F5904 0015 0007	F5904 0015 0008	F5904 0015 0002	F5904 0015 0010	F5904 0015 0001	F5904 0001 0011	F5904 0001 0012
	Slow	F5904 0015 0003	F5904 0015 0013	F5904 0015 0014	F5904 0015 0016	F5904 0015 0016	F5904 0001 0017	F5904 0001 0018
1:20	Snap	F5904 0020 0002	F5904 0020 0003	F5904 0020 0004	F5904 0020 0005	F5904 0020 0001	F5904 0020 0006	F5904 0020 0007
	Slow	F5904 0020 0008	F5904 0020 0009	F5904 0020 0010	F59040020 0011	F5904 0020 0012	F5904 0020 0013	F5904 0020 0014
1:25	Snap	F5904 0025 0003	F5904 0025 0004	F5904 0025 0005	F5904 0025 0006	F5904 0025 0001	F5904 0025 0002	F5904 0025 0007
	Slow	F5904 0025 0008	F5904 0025 0009	F5904 0025 0010	F5904 0025 0011	F5904 0025 0012	F5904 0025 0013	F5904 0025 0014
1:50	Snap	F5904 0050 0002	F59040050 0004	F5904 0050 0003	F5904 0050 0007	F5904 0050 0001	F5904 0050 0006	F5904 0050 0011
	Slow	F5904 0050 0008	F5904 0050 0005	F5904 0050 0014	F5904 0050 0015	F5904 0050 0016	F5904 0050 0017	F5904 0050 0018
1:75	Snap	F5904 0075 0014	F5904 0075 0002	F5904 0075 0003	F5904 0075 0001	F5904 0075 0004	F5904 0075 0005	F5904 0075 0006
	Slow	F5904 0075 0007	F5904 0075 0008	F5904 0075 0009	F5904 0075 0010	F5904 0075 0011	F5904 0075 0012	F5904 0075 0013
1:100	Snap	F5904 0100 0001	F5904 0100 0006	F5904 0100 0003	F5904 0100 0013	F5904 0100 0005	F5904 0100 0014	F5904 0100 0015
	Slow	F5904 0100 0002	F5904 0100 0016	F5904 0100 0018	F5904 0100 0019	F5904 0100 0019	F5904 0100 0020	F5904 0100 0021
1:150	Snap	F5904 0150 0005	F5904 0150 0006	F5904 0150 0007	F5904 0150 0009	F5904 0150 0009	F5904 0150 0010	F5904 0150 0011
	Slow	F5904 0150 0012	F5904 0150 0013	F5904 0150 0014	F5904 0150 0015	F5904 0150 0016	F5904 0150 0017	F5904 0150 0018
1:200	Snap	F5904 0200 0001	F5904 0200 0008	F5904 0200 0006	F5904 0200 0009	F5904 0200 0010	F5904 0200 0007	F5904 0200 0011
	Slow	F5904 0200 0012	F5904 0200 0013	F5904 0200 0014	F5904 0200 0002	F5904 0200 0015	F5904 0200 0016	F5904 0200 0017
1:250	Snap	F5904 0250 0009	F5904 0250 0010	F5904 0250 0011	F5904 0250 0012	F5904 0250 0013	F5904 0250 0014	F5904 0250 0015
	Slow	F5904 0250 0005	F5904 0250 0016	F5904 0250 0013	F5904 0250 0017	F5904 0250 0018	F5904 0250 0019	F5904 0250 0020
1:300	Snap	F5904 0300 0009	F5904 0300 0010	F5904 0300 0011	F5904 0300 0012	F5904 0300 0013	F5904 0300 0014	F5904 0300 0015
	Slow	F5904 0300 0005	F5904 0300 0013	F5904 0300 0013	F5904 0300 0018	F5904 0300 0018	F5904 0300 0019	F5904 0300 0020

*Standard limit switches are equipped with 2, 3, 4, 6, 8, 10 or 12 snap or slow action switches and with pointed cams (PRSL7140PI). Other assemblies and revolution ratios are available upon request. See SF12C request form on page N11. It is possible to assemble up to 12 switches. Maximum ratio 1:9400.

Discount Schedule SC-20





REQUEST FORM FOR NON-STANDARD SF12C LIMIT SWITCHES

N11

Instructions

- Write the number corresponding to the **components** required
- Write the numbers corresponding to the **cams**, the **switches**, the **pinion gear** and the **potentiometers** required
- When a potentiometer is required, mark the box corresponding to the type of **coupling** needed
- Write the **revolution ratio** required for each output

CAMS

- | | | |
|---|---|------------|
| 1 |  | PRSL7140PI |
| 2 |  | PRSL7141PI |
| 3 |  | PRSL7142PI |
| 4 |  | PRSL7143PI |
| 5 |  | PRSL7144PI |

SWITCHES

- | | |
|---|------------------------|
| 1 | PRSL0036XX Snap Action |
| 2 | PRSL0037XX Slow Action |

POTENTIOMETERS

- | | |
|---|---|
| 1 | PRVV9020PE
Megatron 4.7 k
continuous rotation |
| 2 | PRVV9025PE
Megatron 10 k
continuous rotation |
| 3 | PRVV9035PE
Megatron 2.2 k
continuous rotation |
| 4 | PRVV9030PE
MCB 10 k |
| 5 | PRVV9031PE
MCB 10 k
continuous rotation |

MALE COUPLING

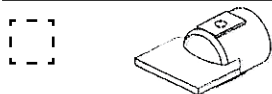

FEMALE COUPLING



FLANGE

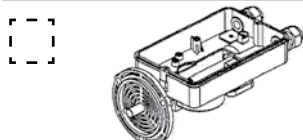

POTENTIOMETERS

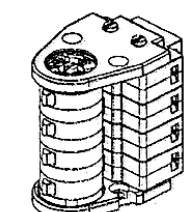
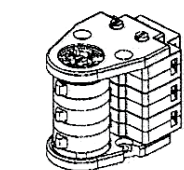
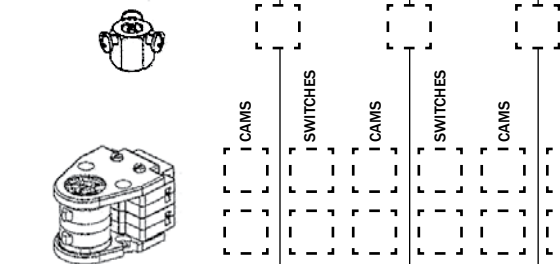
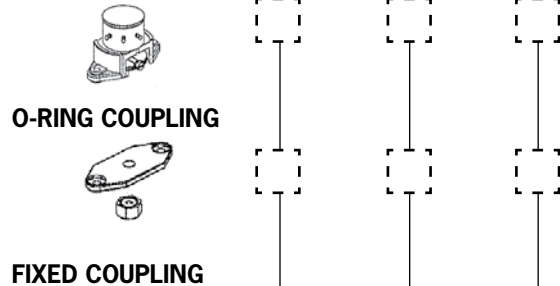

REVOLUTION RATIO

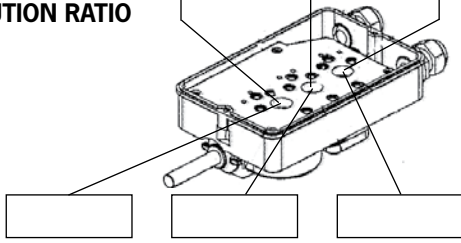

Remarks:

.....

.....

.....

.....

COVER



STANDARD SHAFT



FLEXIBLE SHAFT

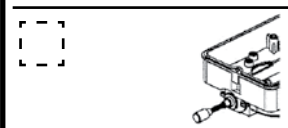

PINION GEARS

- | | |
|---|--------------------|
| 1 | PRSL0911PI M10 Z12 |
| 2 | PRSL0912PI M12 Z10 |
| 3 | PRSL0913PI M14 Z10 |
| 4 | PRSL0914PI M16 Z10 |
| 5 | PRSL0915PI M20 Z8 |
| 6 | PRSL0916PI M5 Z12 |
| 7 | PRSL0917PI M6 Z11 |
| 8 | PRSL0918PI M8 Z12 |
| 9 | PRSL0944PI M12 Z12 |



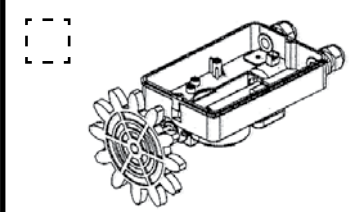



PINION GEAR

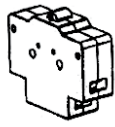

PENDANT STATIONS ACCESSORIES

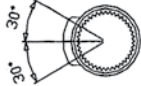
Accessory Parts for all Units

N12

	Description	Part Number	Price
	Snap Action Switch; MF2C	PRSL0003XX	\$65.00
	Snap Action Switch; PF2C, GF4C, SF12C	PRSL0036XX	\$56.00
	Slow Action Switch; PF2C, GF4C, SF12C	PRSL0037XX	\$56.00
	Pointed Cam	PRSL7140PI	\$7.00
	Sector Cam (60°)	PRSL7141PI	\$7.00
	10 Point Cam	PRSL7142PI	\$9.00
	Circular Cam	PRSL7143PI	\$12.50
	180° Cam	PRSL7144PI	\$12.50
	Potentiometer MCB 10k ohm	PRVV9030PE	\$800.00

Technical Specifications

Conformity to Community Directives	73/23/CEE	93/668/CEE		
Conformity to Standards	EN 60204-1 EN 60529	EN 60947-1 EN 418	EN 60947-5-1 EN 50013	IEC 536
Ambient Temperature	Storage Operational	-40°C / +70°C -25°C / +70°C		
Protection Degree		IP 65		
Insulation Category		Class II		
Cable Entry		Rubber Cable Sleeve Ø 14+26mm		
Operating Positions		Any Position		
Homologations		CE, UL, (c)UL		

Technical Specifications of the Contact Switches

Utilisation Category	AC 15
Rated Operational Current	1.9 A
Rated Operational Voltage	380V
Rated Thermal Current	10 A
Rated Insulation Voltage	500V ~
Mechanical Life	1 x 10 ⁶ operations
Terminal Referencing	According to EN 50013
Connections	Screw-Type Terminals
Homologations	CE, UL, (c)UL

Discount Schedule SC-20

ROTARY LIMIT SWITCH - DIMENSIONS

N13

MF2C Dimensions (mm)

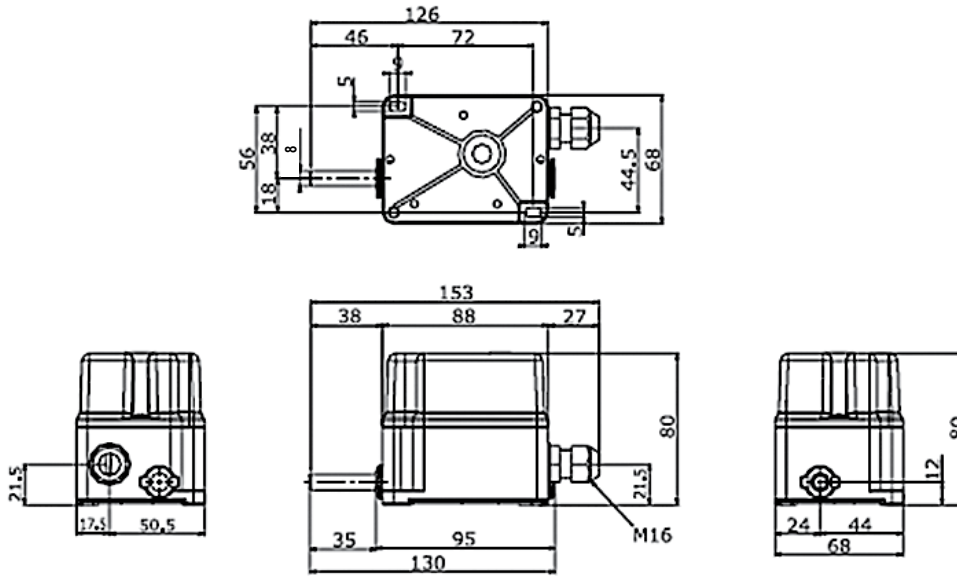

PF2C Dimensions (mm)

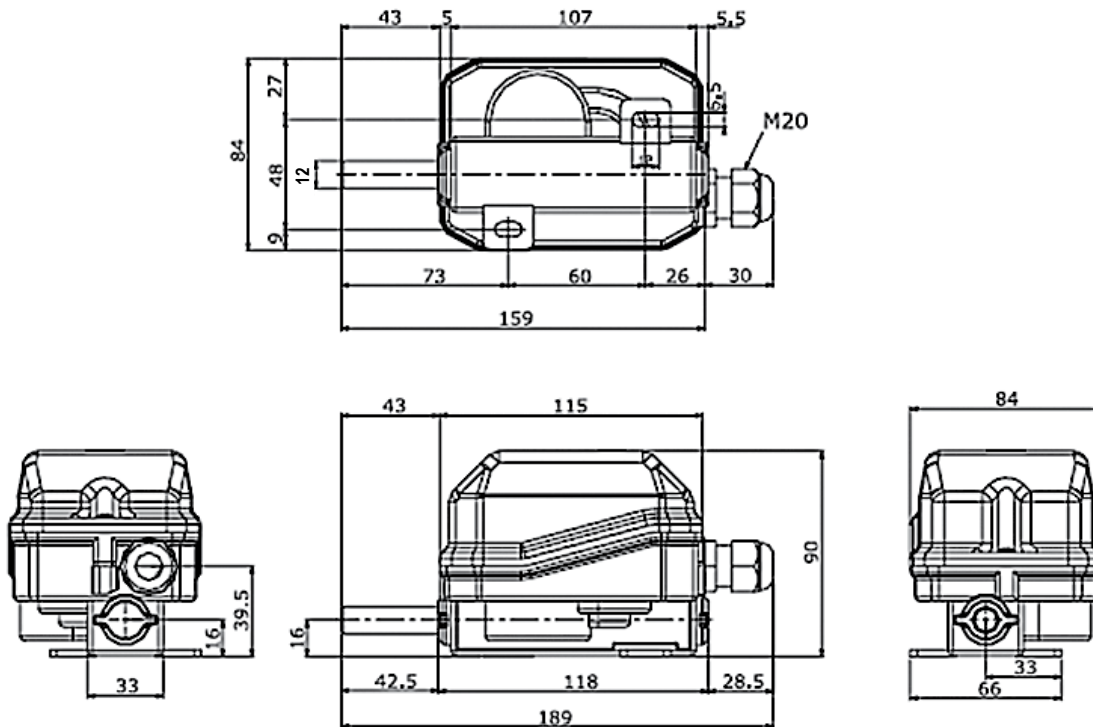

ROTARY LIMIT SWITCH DIMENSIONS

GF4C Dimensions (mm)

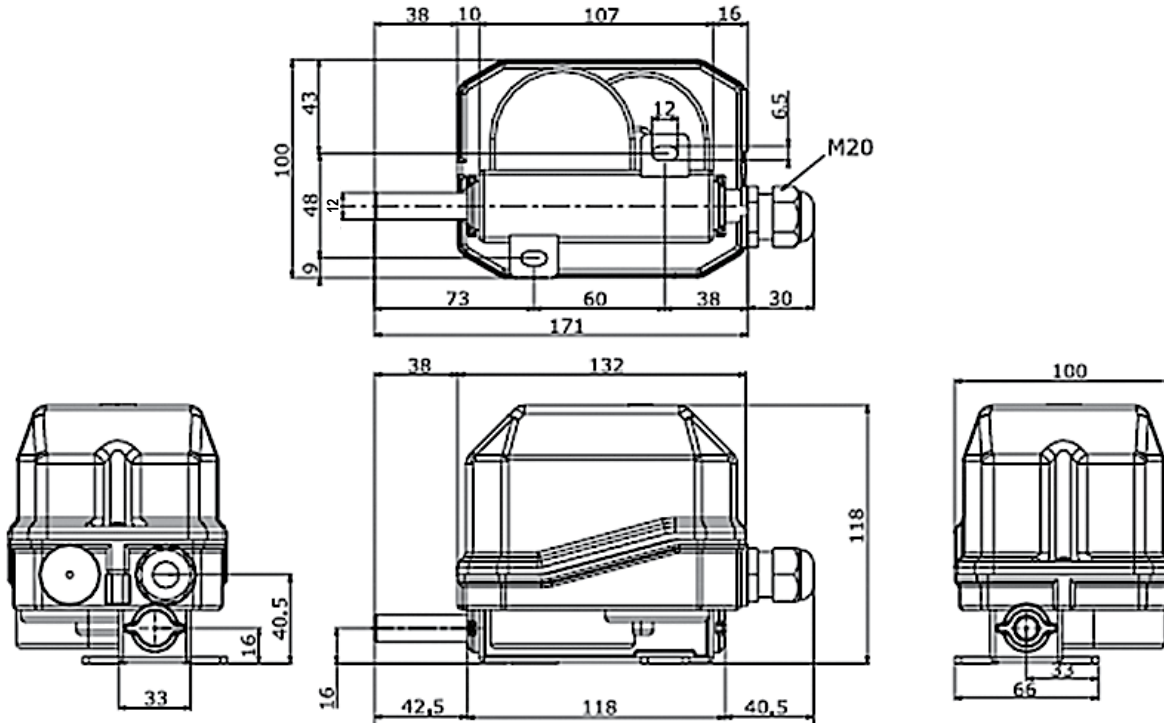

SF12C Dimensions (mm)

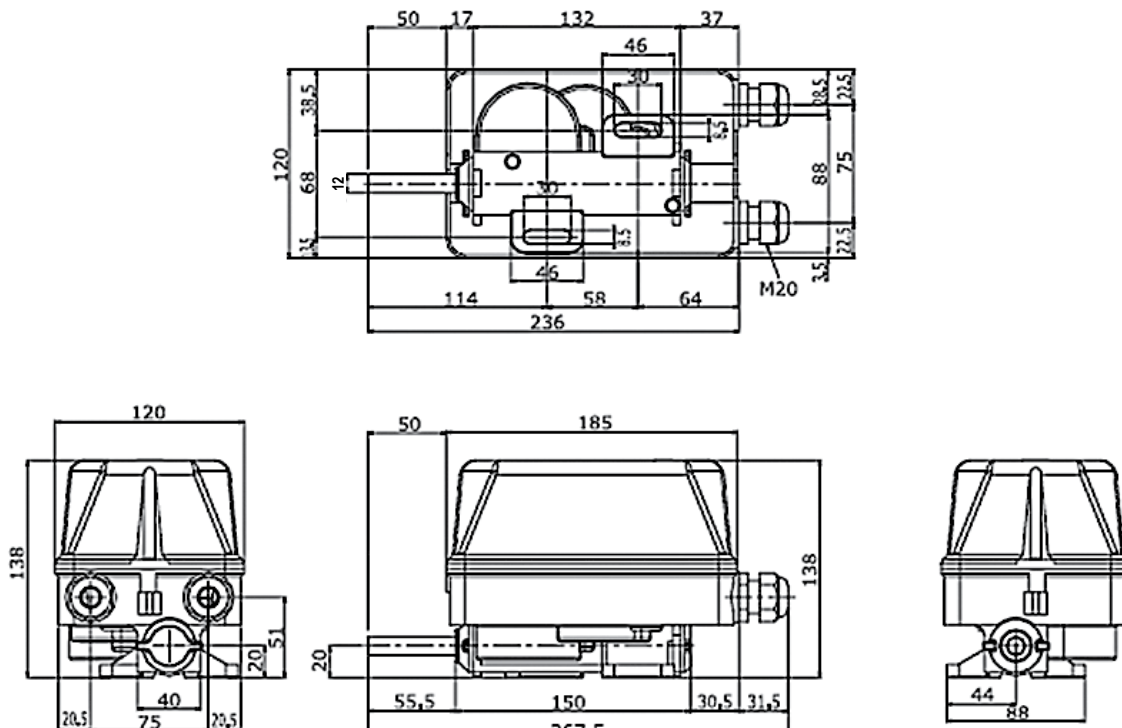

N14

FOOT SWITCHES



SPRINGER
controls company

Index
0

Springer Controls is the North America Distributor for Tecno Elettrica Ravasi®. We offer 2 types of foot switches with either standard or large cover availability. Each model offers outstanding quality, heavy-duty performance and great dependability

Foot Switches

Description / Technical Specifications02

Model Types & Dimensions03

FOOT-SWITCHES; DESCRIPTION & TECHNICAL SPECS

02

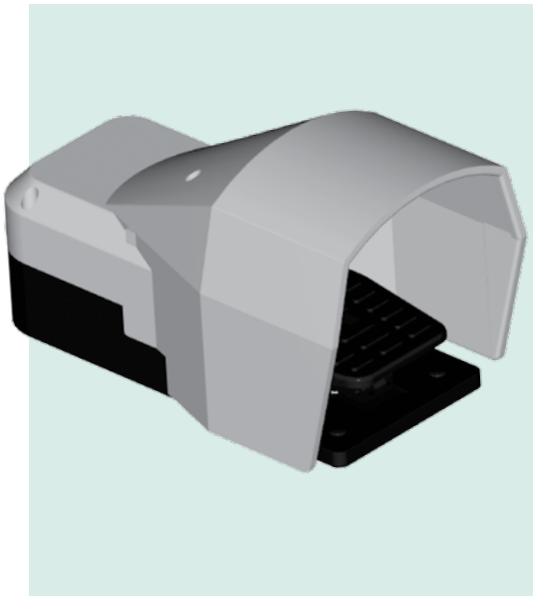

Springer Controls offer a complete line of Tecno Elettrica Ravasi (T.E.R.) series foot switches. The industrial foot switches can be used for the auxiliary control of motors on machine tools, conveyors, lifts, and auxiliary foot operated devices.

Both, shock-resistant thermoplastic and die-cast aluminum units are available, either having a standard cover or a larger cover to fit a safety shoe. All foot switches are fitted with rubber feet to prevent slipping and increase the stability of the equipment, the thermoplastic units have an iron core base to help stability. All are equipped with a safety lock to prevent accidental tripping.

The foot switches are equipped with one or two snap action (1 N.O. + 1 N.C. or 2 N.O. + 2 N.C.) contact elements. The N.C. contacts are of the positive opening type.

Double-unit foot switches are available by request along with "slow-action" contacts or 3 contact switch units. Consult factory.

Foot-Switch Part# & Pricing

Number of Contacts	Contacts	Shock-resistant Thermoplastic Series				Die-cast Aluminium Series			
		Std. Cover Catalog No	Price	Large Cover Catalog No	Price	Std. Cover Catalog No	Price	Large Cover Catalog No	Price
1	1 N.O. + 1 N.C.	PF18620010	\$126	PF54612100	\$145	PF54615100	\$307	PF54617100	\$342
2	2 N.O. + 2 N.C.	PF18620025	\$152	PF54612200	\$171	PF54615200	\$333	PF54617200	\$368

Technical Specifications

Conformity to Community Directives	73/23/CEE	93/68/CEE	
Conformity to Standards	EN 60947-1	EN 947-5-1	EN 60204-1
Ambient Temperature	Storage	-40 °C / +70 °C	
	Operational	-25 °C / +70 °C	
Protection Degree	IP 53		
Insulation Category	Class I		
Cable Entry	Cable Clamp M20		
Approvals	CE (Switches = UL, (c)UL)		
Switch Rated Operational Current	3A		
Switch Rated Operational Voltage	250V		
Switch Rated Thermal Current	10A		

Discount Schedule SC-20

FOOT-SWITCHES; DESCRIPTION & TECHNICAL SPECS

Industrial Foot-Switch; Standard Cover

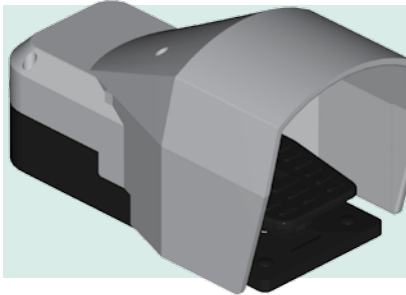

- Available in thermoplastic or die-cast aluminium
- 1 or 2 switch contacts available. (Consult factory for 3 switch)

03

Industrial Foot-Switch; Large Cover

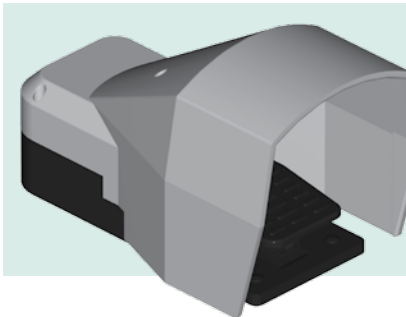

- Available in thermoplastic or die-cast aluminium
- 1 or 2 switch contacts available. (Consult factory for 3 switch)
- Larger Cover; designed for steel toed safety shoes

Industrial Foot-Switch; Double

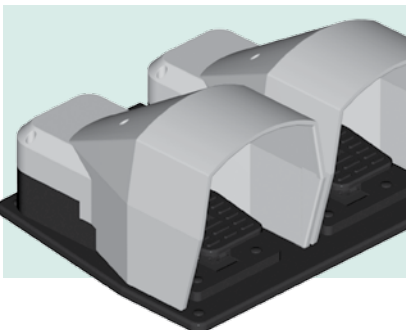

- Consult factory for pricing and availability of a “double foot-switch”
- Double foot-switches are fixed on a metal plate and can be supplied with emergency stop mushroom push-button.

DIMENSIONS (mm)

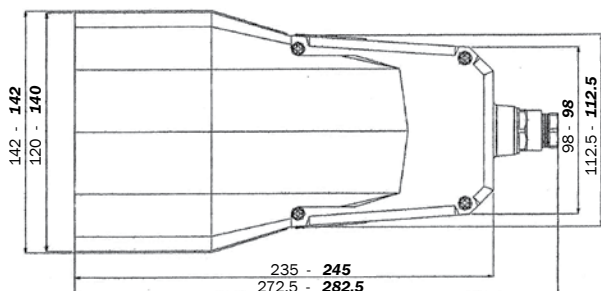
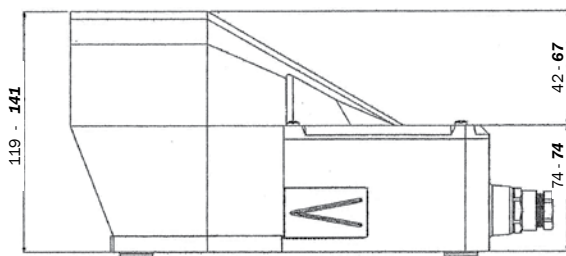

- Foot switch with standard protection
- **Foot switch with large protection**

NOTES

04

POSITION LIMIT SWITCHES

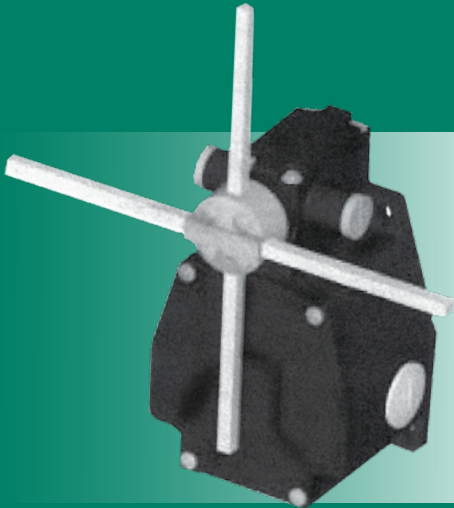

SPRINGER
controls company

Index
P

Springer Controls is the North American distributor for Tecno Elettrica Ravasi (T.E.R.). The Position Limit Switch can be used as control devices for overhead traveling cranes, hoists and machine tools. We offer 3 models; 4 switch (windmill), X-FSC and the X-FRZ. Each style offers outstanding quality, versatile design and rugged dependability.

POSITION (WINDMILL) LIMIT SWITCHES

General Description; 4-switch, X-FSC, X-FRZ	P2
Technical Specifications	P2
Part Number and Pricing.....	P3
Dimensions	P4

GENERAL DESCRIPTION

Position limit switches are control devices for overhead travelling cranes, hoists and machine tools.

They operate as auxiliary controllers of electrical motors through power interfaces, such as controllers or PLCs. Materials and components are wear resistant and protect the equipment against water and dust.

The "4 Switch" limit switch is made of die-cast aluminum and has cross rods which operate 4 switches and move to maintained positions.

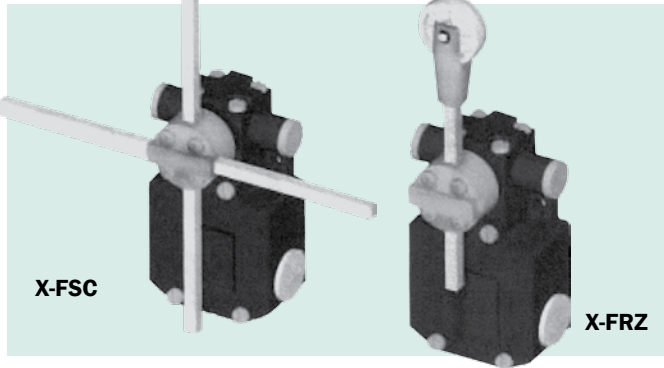
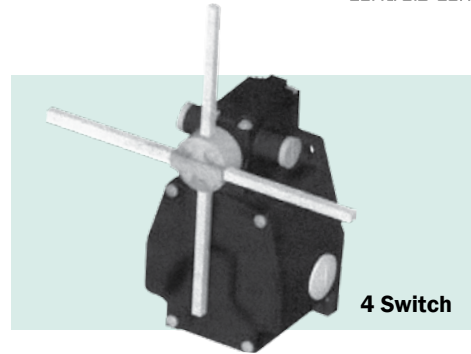

Both the enclosure and the head of the X-FSC limit switch are made of plastic (nylon reinforced with fiberglass) and the "T" or "cross" rods may move to 3 or 4 maintained positions.

The X-FRZ limit switch is made of the same plastic, but it features a single rod or a rod with roller with spring return movements.

The limit switches are equipped with 1 N.O. + 1 N.C. snap action switches or, upon request, with 1 N.C. slow action switches. All switches are of the positive opening type, thus suitable for safety functions.

Technical Specifications

Conformity to Community Directives	73/23/CEE 93/68/CEE
Conformity to Standards	EN 60204-1 EN 60947-1 EN 60947-5-1 EN 60529 EN 50013 IEC 536
Ambient Temperature	Storage; -40°C / +70°C Operational; -25°C / +70°C
Protective Degree	IP 65
Insulation Category	X-FSC and X-FRZ; Class II 4 Switches; Class I
Cable Entry	X-FXC and X-FRZ; cable clamp PG 13,5 4 Switches; cable clamp PG 16
Operating Positions	Any position
Actuating Speed	3m/s max.
Approvals	CE

Technical Specifications of the Switches

Utilisation Category	AC 15
Rated Operational Current	3 A
Rated Operational Voltage	250V
Rated Thermal Current	10 A
Rated Insulation Voltage	300V ~
Mechanical Life	1 x 10 ⁶ operations
Terminal Referencing	According to EN 50013
Connections	Screw-type terminals with self-lifting pads
Approvals	CE UL (c)UL

Actuating Dimensions

"T" rods - Cross rods with 3 maintained positions	
Pre-travel angle for contact operation	70° - 49°
Maximum rotation angle	90°
Average angle for the mechanical tripping	48°
Rod - Rod and roller	
Pre-travel angle for contact operation	24°
Maximum rotation angle	65°
Cross rods with 4 maintained positions	
Pre-travel angle for rotation contact operation	49°
Maximum rotation angle for each maintained position	90°
Average angle for the mechanical tripping	48°
Maintained positions each	90°

Series	Control Element	Positions	Actuating Travel	Catalog No.	Price	
4 Switches	Cross Rods	4 maintained		PF26755100	\$821.00	
X-FSC	"T" Rods	3 maintained		PF33710100	\$463.00	
				PF33711100	\$463.00	
				PF33712100	\$463.00	
				PF33713100	\$463.00	
				PF33714100	\$463.00	
				PF33715100	\$463.00	
				PF33710200	\$463.00	
				PF33711200	\$463.00	
				PF33712200	\$463.00	
	Cross Rods	3 maintained		PF33713200	\$463.00	
				PF33714200	\$463.00	
				PF33715200	\$463.00	
				PF33750100	\$507.00	
				PF33751100	\$507.00	
				PF33752100	\$507.00	
				PF33753100	\$507.00	
				PF33753100	\$507.00	
				PF33753100	\$507.00	
	X-FRZ	Rod	Spring Return		PF33700100	\$449.00
					PF33701100	\$449.00
					PF33702100	\$449.00
				PF33703100	\$449.00	
				PF33704100	\$449.00	
				PF33705100	\$449.00	
Rod & Roller		Spring Return		PF33700200	\$470.00	
				PF33701200	\$470.00	
				PF33702200	\$470.00	
				PF33703200	\$470.00	
				PF33704200	\$470.00	
				PF33705200	\$470.00	

DIMENSIONS

4 Switches (mm)

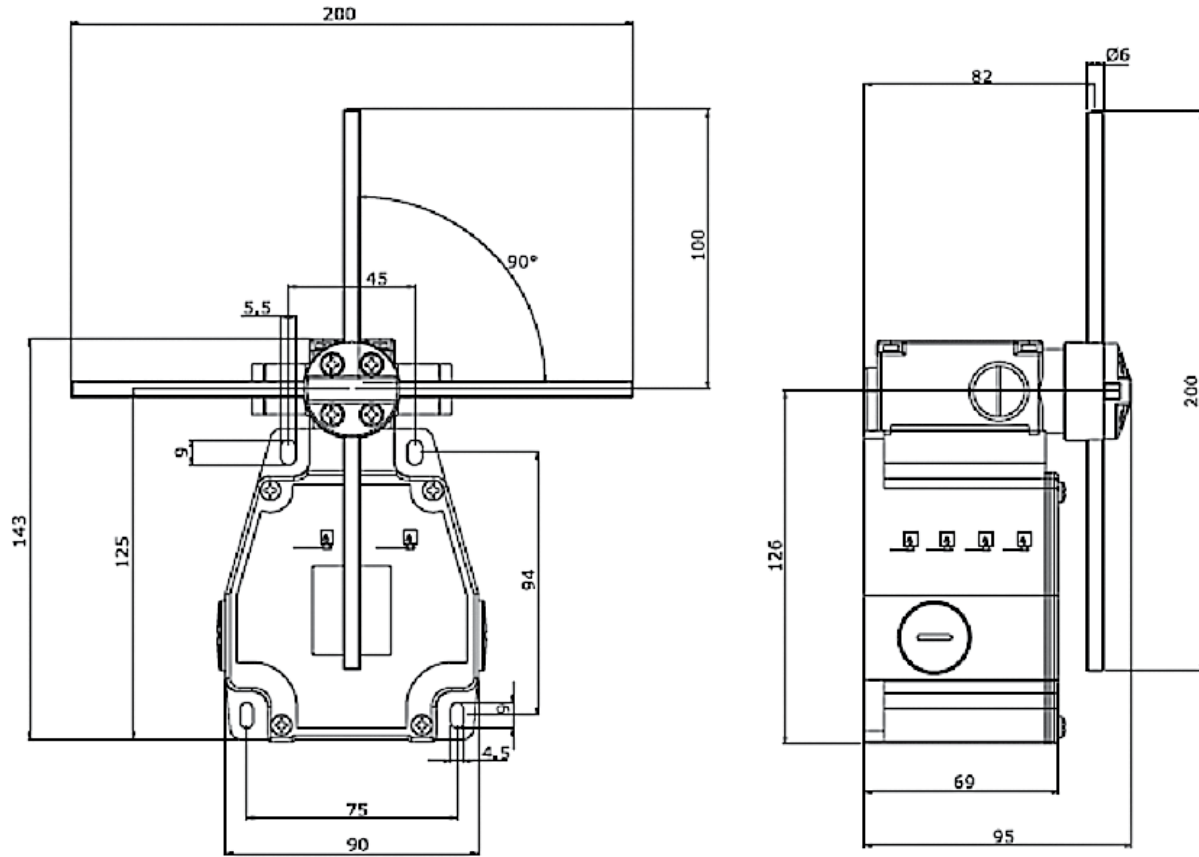

X-FSC / X-FRZ (mm)

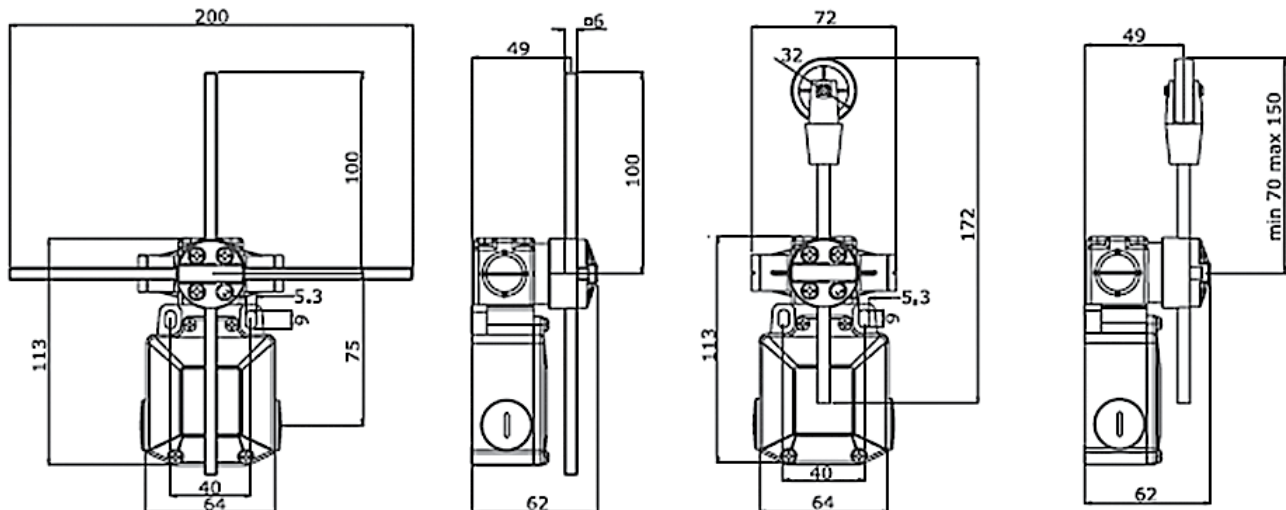



SPRINGER
controls company

Springer Controls is the North American distributor for Tecno Elettrica Ravasi® joysticks. **Springer Controls** offers 2 models of industrial joysticks; **CK Series** and **PM Series**. Each offers outstanding quality, versatile design and rugged dependability. All joystick models can be custom made to meet your specifications.

INDUSTRIAL JOYSTICKS

CK JOYSTICKS

Features	Q2
Technical Specifications	Q2
Standard Unit Part No. & Pricing	Q2
Dimensions & Replacement Parts	Q3

PM JOYSTICKS

Features	Q4
Technical Specifications	Q4
Standard Unit Part No. & Pricing	Q4
Dimensions & Replacement Parts	Q5

FEATURES - CK SERIES

Joysticks - CK Series

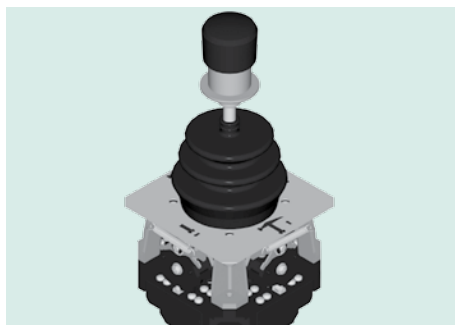

- Large Heavy Duty
- Standard units come with spring action return and mechanical interlock handle (360° movement unless otherwise noted)
- Up to 5 steps in each direction
- Potentiometer / variable speed available
- Custom Joysticks available
- UL - cUL contact switches

Q2

Technical Specifications - CK Series

Conformity to Community Directives	73/23/CEE 93/68/CEE
Conformity to Standards	EN 60204-1 EN 60947-1 EN 60947-5-1 EN 60529 EN 418 EN 50013 IEC 536
Ambient Temperature	Storage; -40°C / +70°C Operational; -25°C / +70°C
Protective Degree	IP 00
Operating Positions	Any position
Weight	900g
Homologations	CE

Technical Specifications - Switches

Utilisation Category	AC 15
Rated Operational Current	1.9 A
Rated Operational Voltage	380V
Rated Thermal Current	10 A
Rated Insulation Voltage	500V~
Mechanical Life	.5 x 10 ⁶ operations
Connections	Screw-type Terminals
Homologations	CE UL (c)UL

Part No. & Pricing*: Standard units come with spring action return and mechanical interlock handle (360° movement.)

Steps Up-Down	Steps Right-Left	Catalog No.	Price
1	0	PF08020378	\$746.00
2	0	PF08020004	\$796.00
3	0	PF08020003	\$847.00
3	1	PF08010005	\$950.00
3	2	PF08010016	\$1000.00
3	3	PF08010002	\$1050.00
4	0	PF08020076	\$900.00
4	1	PF08010017	\$1000.00
4	3	PF08010039	\$1102.00
5	0	PF08020215	\$950.00
5	1	PF08010007	\$1051.00
5	3	PF08010012	\$1152.00
5	5	PF08010003	\$1255.00

*Consult factory for “maintained” style, potentiometer style, or cross-movement custom joysticks.

Discount Schedule SC-20

DIMENSIONS & REPLACEMENT PARTS

Dimensions

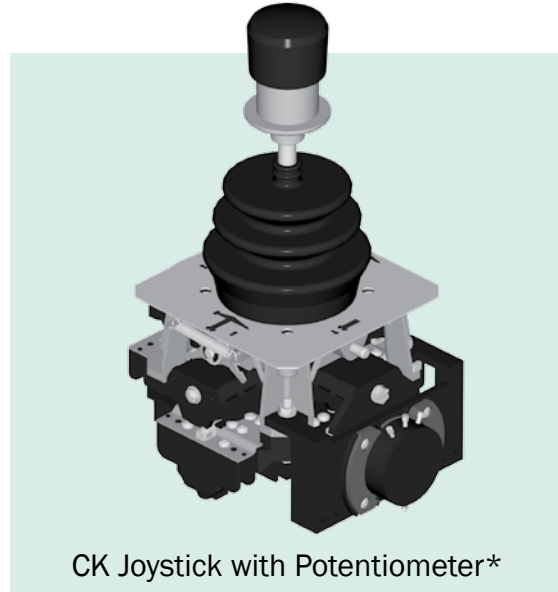
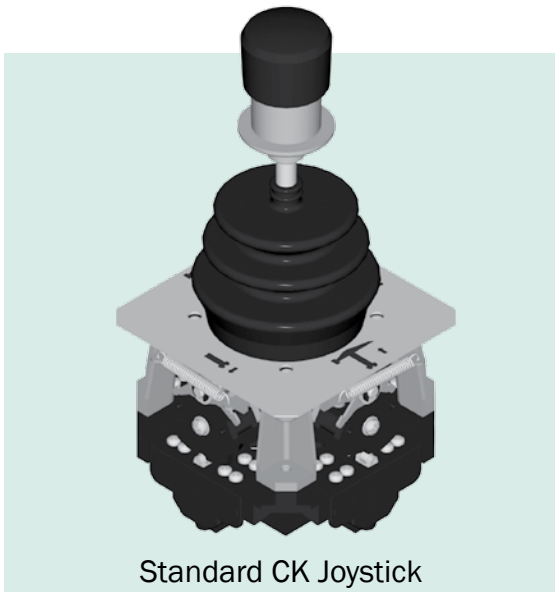

Q3

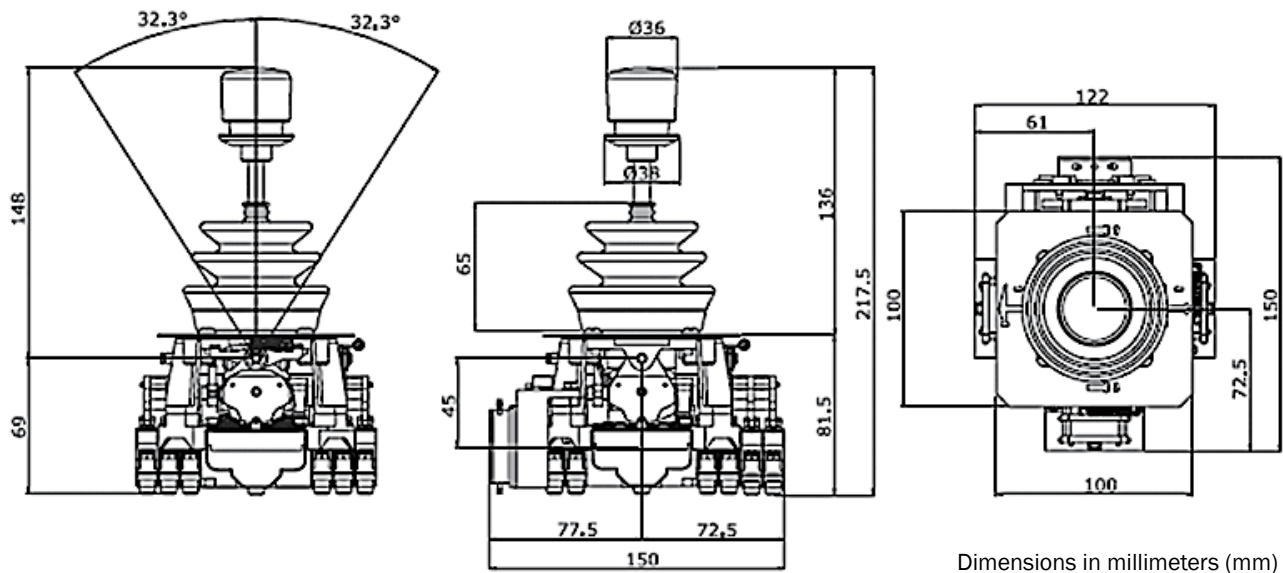

Replacement Parts & Pricing

Description	Catalog No.	Price
Bellow / Gasket	PRGU6040PE	\$67.00
Potentiometer - 10k	PRVV9025PE	\$800.00
1 Normally Open Switch	PRSL0007XX	\$54.00

*Consult factory for joysticks with potentiometer or any custom joysticks

Discount Schedule SC-20

FEATURES - PM SERIES

Joysticks - PM Series



- Small Compact Size
- Standard units come with spring action return and mechanical interlock handle (360° movement.)
- Up to 5 steps in each direction
- Custom Joysticks available

Technical Specifications - PM Series

Conformity to Community Directives	73/23/CEE 93/68/CEE
Conformity to Standards	EN 60204-1 EN 60947-1 EN 60947-5-1 EN 60529 EN 418 EN 50013 IEC 536
Ambient Temperature	Storage; -40°C / +70°C Operational; -25°C / +70°C
Protective Degree	IP 00 (IP 65 max. when assembled in specific enclosure)
Operating Positions	Any position
Weight	250g
Homologations	CE

Technical Specifications - Switches

Utilisation Category	AC 15
Rated Operational Current	2 A
Rated Operational Voltage	48V
Rated Thermal Current	8 A
Rated Insulation Voltage	60V~
Mechanical Life	0,5 x 10 ⁶ operations
Connections	2,8mm Faston taps / terminal board
Homologations	CE

Part No. & Pricing*: Standard units come with spring action return and mechanical interlock handle (360° movement.)

Steps Up-Down	Steps Right-Left	No. Switches	Catalog No.	Price
1	0	2	F340210000004	\$394.00
1	1	4	F340211000001	\$538.00
1	2	5	F340212000001	\$612.00
1	3	6	F340213000001	\$683.00
1	5	8	F340215000001	\$827.00
2	0	3	F340220000004	\$470.00
2	2	6	F340222000001	\$688.00
2	3	7	F340223000001	\$757.00
3	0	4	F340230000004	\$538.00
3	3	8	F340233000001	\$827.00
3 cross	3 cross	8	F340233000004	\$827.00
3	5	10	F340235000001	\$970.00
4	0	5	F340240000004	\$612.00
5	5	12	F340255000001	\$1114.00
5 cross	5 cross	12	F340255000004	\$1114.00

*Consult factory for “maintained” style, potentiometer style, or cross-movement custom joysticks.

Discount Schedule SC-20

DIMENSIONS & REPLACEMENT PARTS

Dimensions

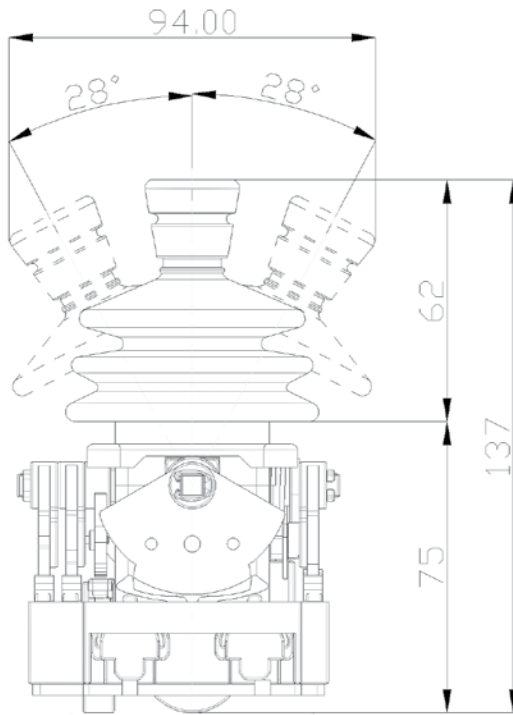

Dimensions in millimeters (mm)

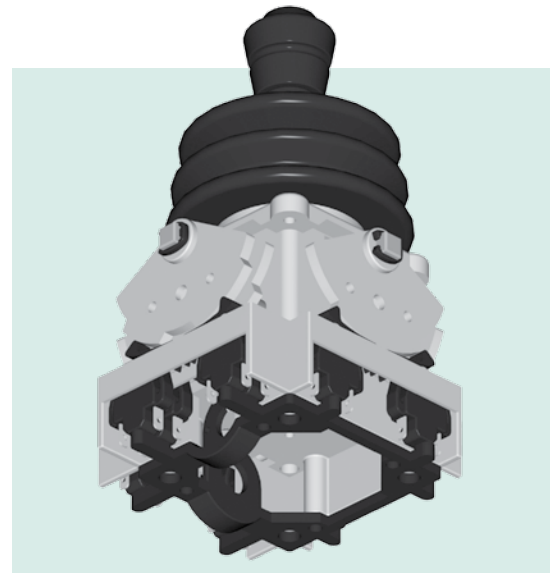
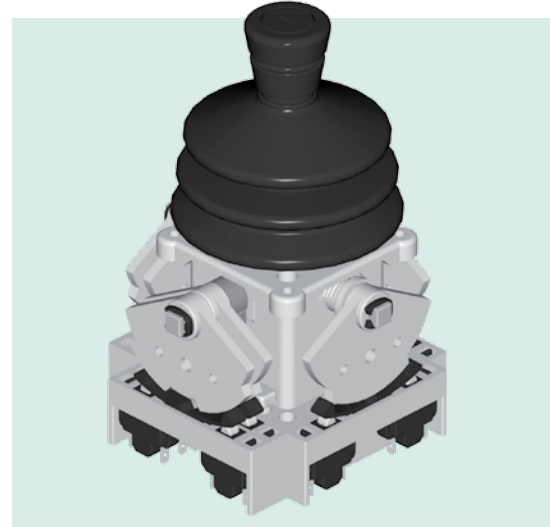
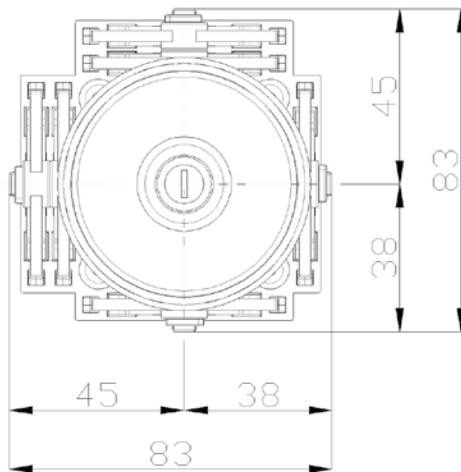

Q5

Replacement Parts & Pricing

Description	Catalog No.	Price
5 Position Switch Board	93546	Consult Factory
3 Position Switch Board	93557	Consult Factory
Bellow / Gasket	PRGU6042PE	\$42.00

Discount Schedule SC-20

NOTES

Q6